



FORM NO. 1-667R7

October 2005

Price: \$5.00

QUIK-LIFT® power unit service manual

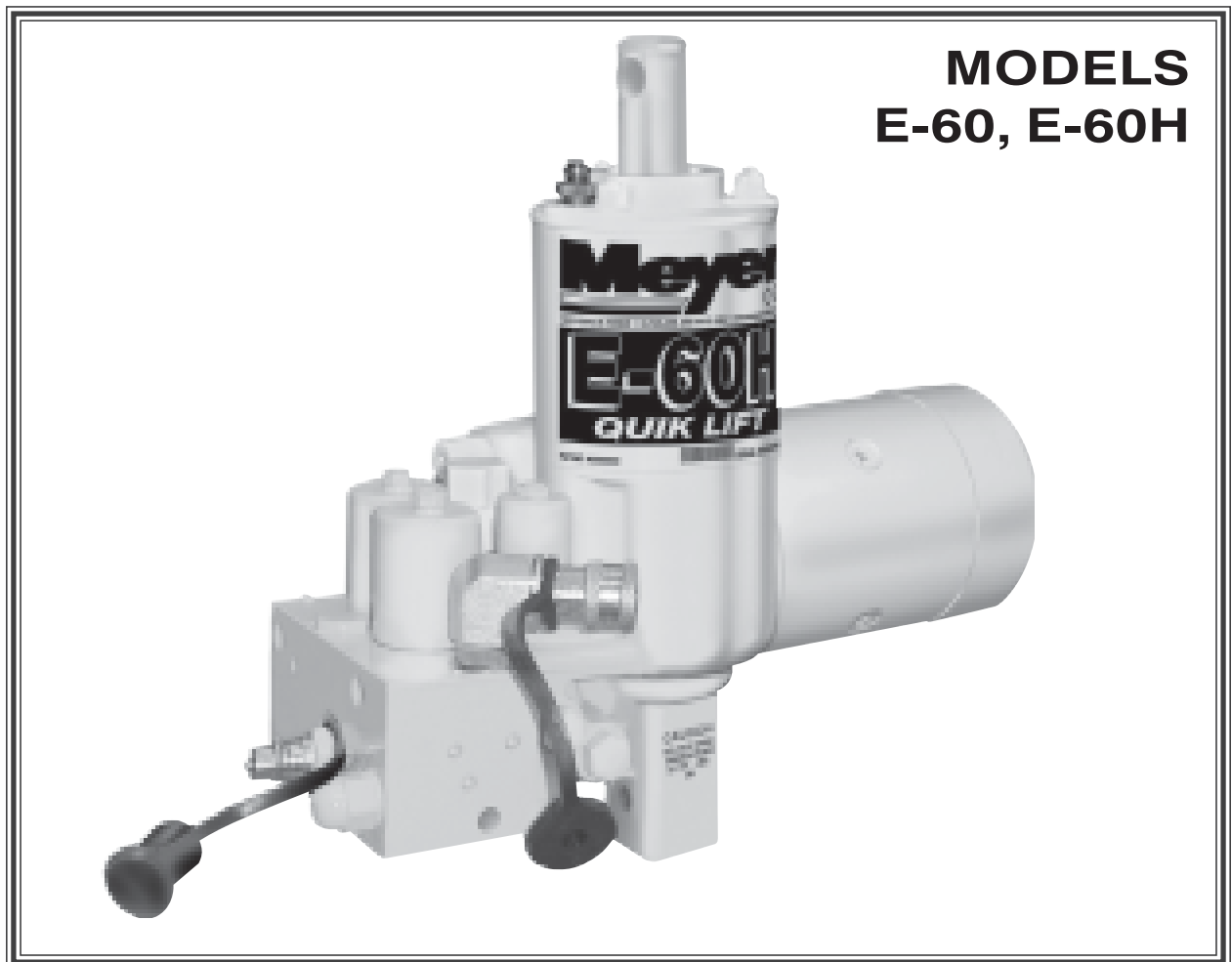

Meyer Products
18513 Euclid Ave. • Cleveland, OH 44112-1084
Phone (216) 486-1313
email • warranty@meyerproducts.com
© 2005 Printed in the U.S.A.



Diamond Equipment
6 Angell Lane • Damariscotta, ME 04543-9720
Phone (207) 563-2227
www.diamondplow.com • email info@diamondplow.com

FOREWARD

This Service Manual includes complete information for servicing the following Quik-Lift® E - 60, E - 60H Units:

The information is grouped according to the type of work being performed, such as diagnosis and testing, disassembly and reassembly. Special tools and specifications are also included in this manual.

All information, illustrations and product descriptions contained in this manual are correct at publication time. We do, however, reserve the right to make changes at any time without prior notice.

MEYER PRODUCTS

IMPORTANT: Maintenance and repairs must be performed with the moldboard on the ground.

SECTION INDEX

Section Number	Section Title	Page
0	GENERAL INFORMATION AND MAINTENANCE	1
1	GENERAL DESCRIPTION AND THEORY OF OPERATION	4
2	DIAGNOSIS	18
3	REPAIR PROCEDURE	25
4	SPECIFICATIONS	53



E-60

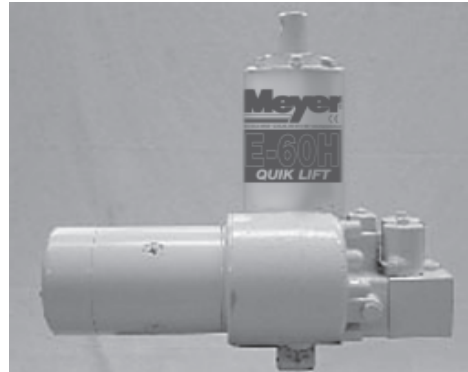

E-60H

Meyer Products reserves the right, under its continuing product improvement program, to change construction or design details, specifications and prices without notice or without incurring any obligation.

SECTION 0 - GENERAL INFORMATION AND MAINTENANCE

CONTENTS

- GENERAL INFORMATION 2
 - MODEL IDENTIFICATION 2
 - MODEL IDENTIFICATION AND SERIAL NUMBER LOCATION 2
 - MOTOR IDENTIFICATION 2
- MAINTENANCE 2
 - GENERAL MAINTENANCE 2
 - CLEANLINESS 2
 - VEHICLE ELECTRICAL SYSTEM 3
 - CHECK REGULARLY 3
- POST-SEASON MAINTENANCE 3
 - MEYER HYDRAULIC FLUID M-1 3
 - REPLACEMENT OF HYDRAULIC FLUID 3
 - FILTERS 3
 - PROTECTION AGAINST RUST AND CORROSION 3

GENERAL INFORMATION

Model Identification

The Quik Lift® unit is an electrically powered hydraulic mechanism specifically designed for use with the Meyer Snow Plow and is available in four models as follows:

E-60	Raises, lowers and angles plow hydraulically (7-way) and is used with TM, ST and C series Snow Plows.
E-60H	Raises, lowers and angles plow hydraulically (7-way) and is used with the MDII, HM and Diamond Series (Trip Edge) Snow Plows.

Model Identification and Serial Number Location

Inclusion of the model number and serial number is extremely important when writing up warranty claim forms and product report forms for proper evaluation and follow up.

The basic model number is located on the name plate located as shown in Figure 0-1. To determine whether it is the standard or "H" model, measure the dimension shown in Figure 0-1. The serial number is located on the bottom of the base or on the name plate.

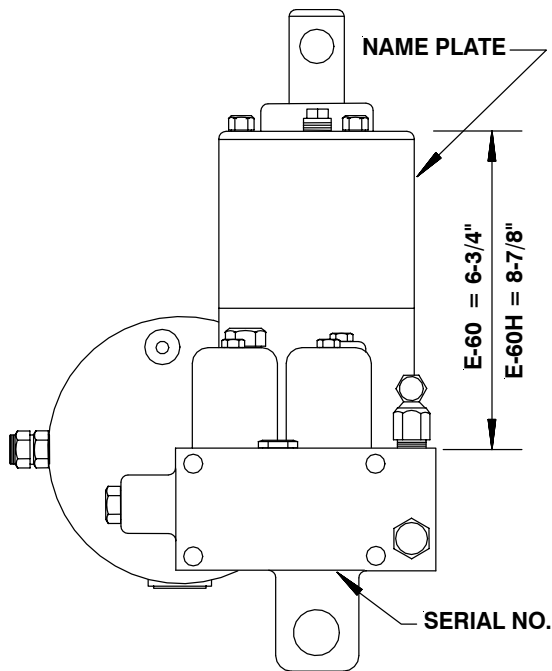
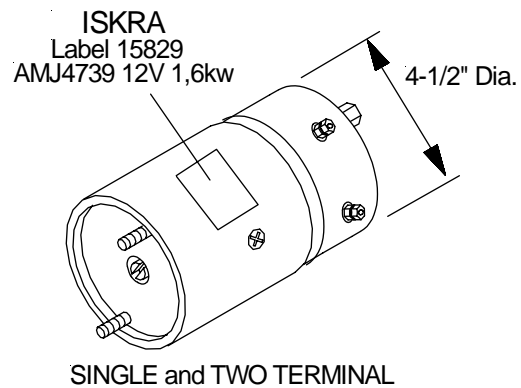
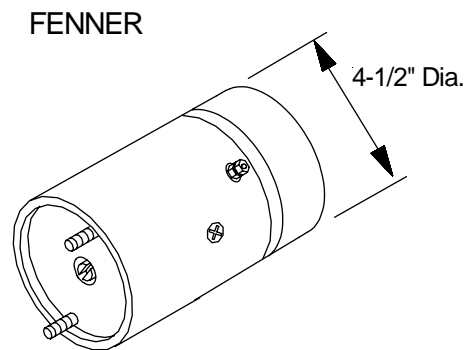

FIGURE 0-1

Motor Identification

Two different brand motors are used on the Quik-Lift® units, Fenner (single terminal) and Iskra. The Iskra motors used in production could be either a single terminal or a two terminal motor. Proper identification of the brand and supplier part number is necessary when seeking local parts and service sources. Note: Brush Kits are the only replacement part available thru Meyer Products.

The motor with which a specific Quik-Lift® unit is equipped can be identified by the distinctive characteristics shown in figure 0-2.



SINGLE and TWO TERMINAL

FIGURE 0-2

MAINTENANCE

The following maintenance information is intended as a basic guide for providing the Quik-Lift® unit with the proper service and care. Sustained heavy duty operation or operating under adverse conditions may necessitate more frequent servicing.

General Maintenance

Cleanliness

The greatest enemy to any hydraulic system is dirt or contamination. Therefore, cleanliness must be stressed at the time of installation, servicing and repairing.

Vehicle Electrical System

Maximum performance and efficiency of the Quick-Lift® unit requires that the vehicle's electrical system be properly maintained and consist of:

Battery -----	70 Amp. Hr. Minimum or 550 Cold Cranking Amps.
Alternator -----	60 Amp. Minimum

Check Regularly

1. Battery Terminals - Must be clean and free of corrosion.
2. Electrical Connections - Must be free of corrosion and tight.
3. Battery - Must be in first-class condition.
4. Alternator (or Generator) and Regulator - Must be functioning to specifications.
5. Hydraulic Fluid Reservoir Level - A significant drop in hydraulic fluid level indicates a leak which must be located and corrected. Insufficient hydraulic fluid may result in severe damage.

POST-SEASON MAINTENANCE

Meyer Hydraulic Fluid M-1.

Meyer Hydraulic Fluid M-1 is a specially formulated mineral oil which maintains an almost constant viscosity from normal to sub-zero temperatures. Because it remains free flowing at extremely low temperatures, the performance and efficiency are not affected.

Meyer Hydraulic Fluid M-1 also contains an additive which neutralizes moisture accumulating in the fluid due to condensation. It is effective for a maximum of one year's use.

Meyer Products will not be liable for damages resulting from the use of inferior or other fluids or oils.

Replacement of Hydraulic Fluid

After a season's use, completely drain the hydraulic fluid (including hydraulic fluid in hoses and cylinders on Power Angling models). Drain fluid through filler hole shown in Figure 0-3 or drain hole in base by completely retracting lift rod and unbolting unit to pour fluid out or using a suction pump. Disconnect the fittings at the Angling cylinders, completely retract the cylinder rods and purge cylinders and hoses of all hydraulic fluid. Flush the complete system including unit, hoses and Power Angling rams with a non wax (Napthenic) cleaner. If kerosene (Parrafinic) is used to flush the system, the system must be flushed again to remove any kerosene with a (Napthenic) based cleaner that is wax free .

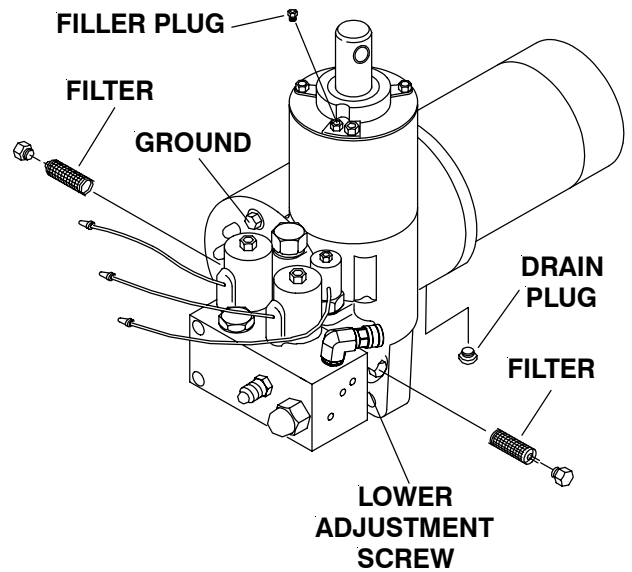

FIGURE 0-3

Refill Quick-Lift® unit with M-1 Fluid by fully retracting lift rod (Ram) and filling reservoir to 1-1/2 " below the filler hole. Fill and bleed hoses and Power Angling cylinders by loosening hydraulic fittings at cylinders until they leak. Power angle plow repeatedly from one side to the other until fluid flows steadily from the leaking fittings while maintaining a constant check on the reservoir fluid level.

Raise and lower the plow several times and with lift rod fully retracted, give a final check to the fluid level and replace filler plug.

Filters

Clean the two filters located in base of unit with mineral spirits or equivalent and blow out with compressed air. See Figure 0-3 for filter locations.

Protection Against Rust and Corrosion

When the Quik-Lift® unit is not used for extended periods, protect the chromed lift rod (Ram) by fully extending it and coating it with chassis lubricant. Full extension of the lift rod (Ram) fills the cylinder with hydraulic fluid. Coat the exposed portions of the Power Angling cylinder rods (Rams) with chassis lubricant to protect them against rust and corrosion.

SECTION 1 - GENERAL DESCRIPTION AND THEORY OF OPERATION

CONTENTS

GENERAL DESCRIPTION	5
THEORY OF OPERATION	5
• FUNCTIONS	5
•• Model E-60	5
•• Model E-60H	5
• ELECTRICAL AND FLOW CHARTS	6-13
QUIK-LIFT® UNIT COMPONENTS	14
• MOTORS	14
•• Fenner	14
•• Iskra	14
• HYDRAULIC PUMP	14
• PRESSURE RELIEF VALVE	14
• SOLENOID VALVES	15
•• Cartridge	15
•• Coil	15
“A” Solenoid Valve	15
“B” Solenoid Valve	15
“C” Solenoid Valve	15
• CHECK VALVES	16
• PILOT CHECK VALVE	16
• CROSSOVER RELIEF VALVES	16
• SWITCHES	17
•• ELECTRO-TOUCH PAD	17
•• SOLENOID SWITCH	17
• FILTERS	17

GENERAL DESCRIPTION

Quik-Lift® unit is an electrically powered and electrically controlled hydraulic mechanism specifically designed for use with Meyer Snow Plows. In addition to raising and lowering the plow hydraulically, the model E-60, E-60H angles the plow hydraulically, left and right, via remote hydraulic cylinders.

The Quik-Lift® unit consists of a specially designed high torque 12-volt DC motor which is directly coupled to a gear-type hydraulic pump. The pump obtains its supply of hydraulic fluid from an integral reservoir which totally surrounds the integral hydraulic cylinder which raises and lowers the plow.

Included in all models is an electrically controlled and powered solenoid valve cartridge "A" which is energized to allow the plow to lower by gravity.

The models E-60 & E-60H include an integral valve body which contains two additional electrically controlled solenoid valve cartridges. Solenoid valve cartridge "B" is energized to route the pressurized hydraulic fluid to the integral hydraulic cylinder to raise the plow. Solenoid valve cartridge "C" is energized to route the pressurized hydraulic fluid to the left remote hydraulic cylinder to angle the plow to the right. Angling the plow to the left only requires energizing the electric motor since the normal route for the pressurized hydraulic fluid is to the right remote hydraulic cylinder.

Additional components which control and supply electrical current to the Quik-Lift® unit are an operator controlled touch pad; a solenoid switch to supply high amperage current to the unit's motor; a wiring harness to distribute low amperage current between the toggle switch or switches, motor solenoid and the solenoid valve cartridge(s); and short heavy gauge cables to distribute high amperage current directly from the positive terminal of the vehicle's battery and ground the unit directly to the negative terminal of the vehicle's battery.

THEORY OF OPERATION

FUNCTIONS

The Quik-Lift® models perform basic functions.

Models E-60 and E-60H

The four basic functions performed are:

- Raise snow plow
- Lower snow plow
- Angle snow plow to right
- Angle snow plow to left

Refer to pages 6 thru 13 for electrical and hydraulic flow chart for each function. Each figure explains which component is actuated and related in each function.

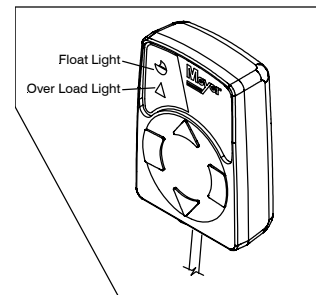
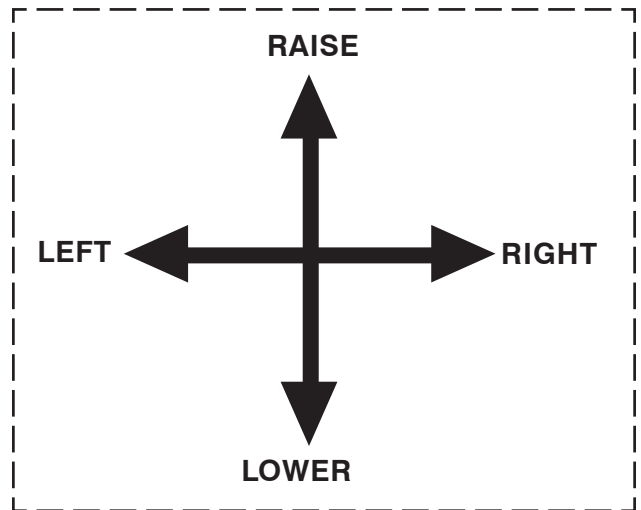

The **current 22154 Electro-Touch Control** has been redesigned. The Touch Pad now has raised buttons and its circuitry has been changed from analog to digital, functions have not changed. For troubleshooting for power at the solenoids do not disconnect wires. To check for power, prick the wire through the insulation for testing.

This **Electro-Touch Control** knows when a short or an open connection occurs and will go into overload mode for the function being activated. To reset the Touch Pad turn the switch on and off. The **Electro-Touch Control** will not operate if not wired properly as per the installation instructions Forms 1-690 or 1-759.

RAISE E-60 and E-60H

When the Electro-Touch® control switch is powered up, yellow lights illuminate the location of the individual arrows for the function of the snow plow: Up, Left, Right and Down.

CAUTION:

When the snow plow is not in operation, the Electro-Touch® control switch should be in the "OFF" position.

IMPORTANT:

The power lead (blue wire with fuse) should be connected to a terminal on fuse panel that is **HOT ONLY** when the ignition switch is in the "ON" position.

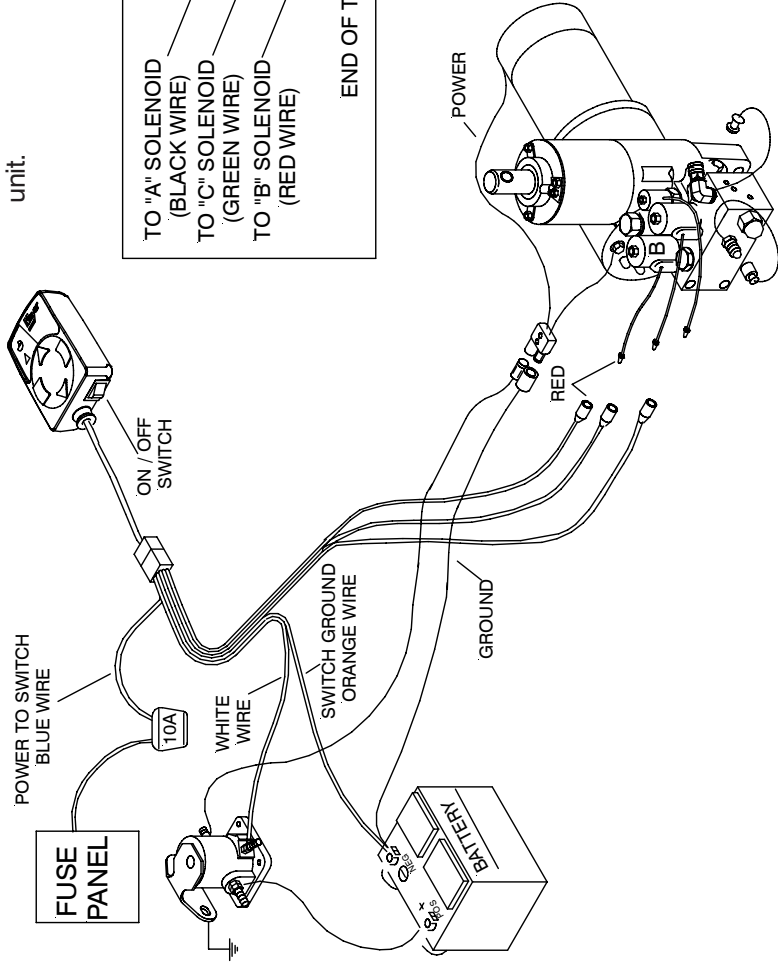

When the Up arrow is activated, electric power is sent to both the **MOTOR & "B" Solenoid** via wiring harness.

MOTOR SOLENOID

Electric power is sent to this solenoid by the **WHITE** wire. This wire connects to the small terminal on the motor solenoid. This wire activates the solenoid switch, allowing electrical power from the vehicle battery to pass through the solenoid to the lift motor via cables.

NOTE: Motor Solenoid must have a good ground to operate properly.

"B" SOLENOID

Electrical power is sent to this solenoid by the **"RED"** wire. This solenoid, when energized, directs hydraulic fluid to the lift cylinder.

NOTE: See illustration below for proper location of **"B"** Solenoid on the lift unit.

E-60 AND E-60H RAISE

E-60 AND E-60H RAISE FLOW CHART

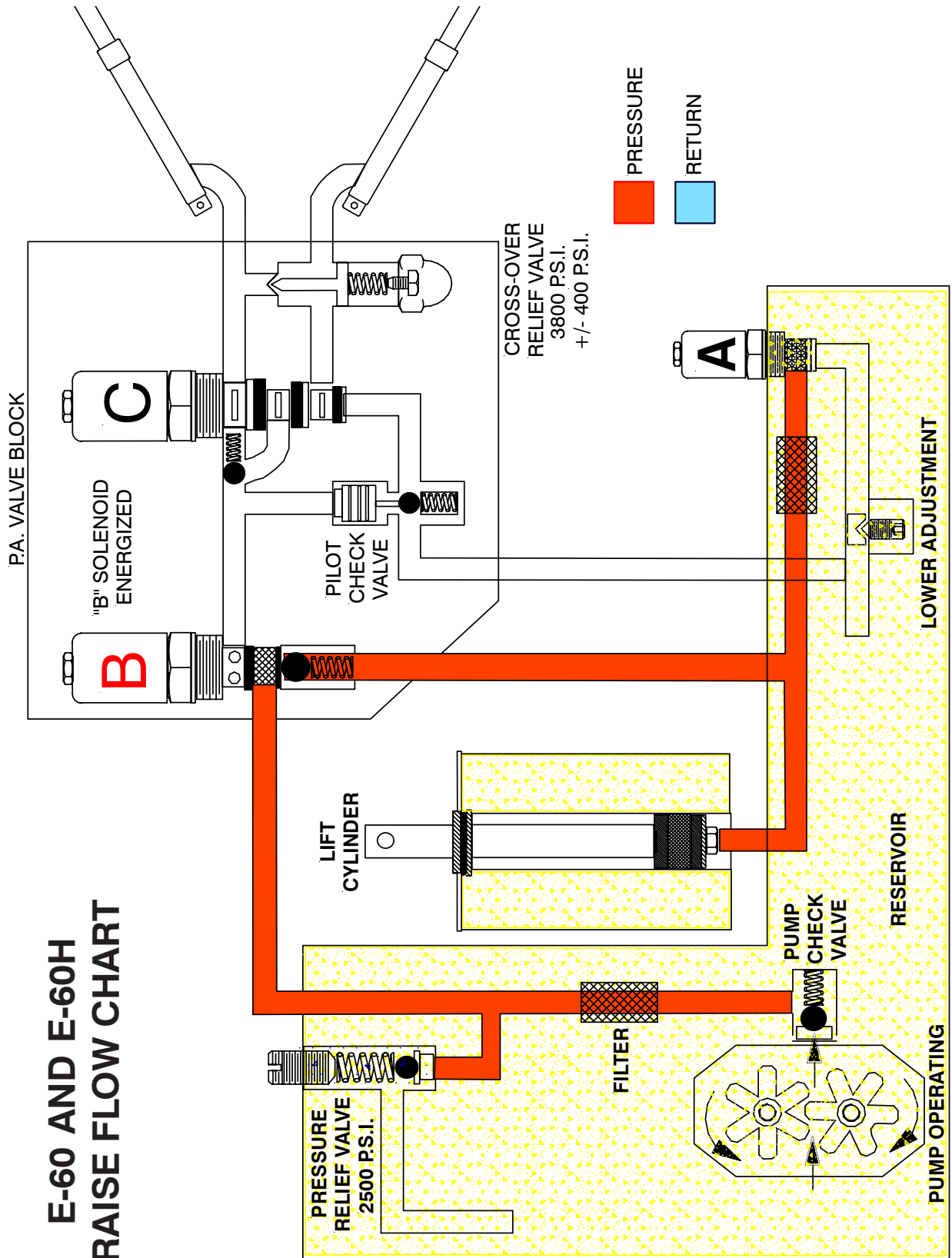

LOWER / FLOAT E-60 and E-60H

When the Electro-Touch® control switch is powered up, yellow lights illuminate the location of the individual arrows for the function of the snow plow: Up, Left, Right and Down.

CAUTION:

When the snow plow is not in operation, the Electro-Touch® control switch should be in the "OFF" position.

IMPORTANT:

The power lead (blue wire with fuse) should be connected to a terminal on fuse panel that is **HOT ONLY** when the ignition switch is in the "ON" position.

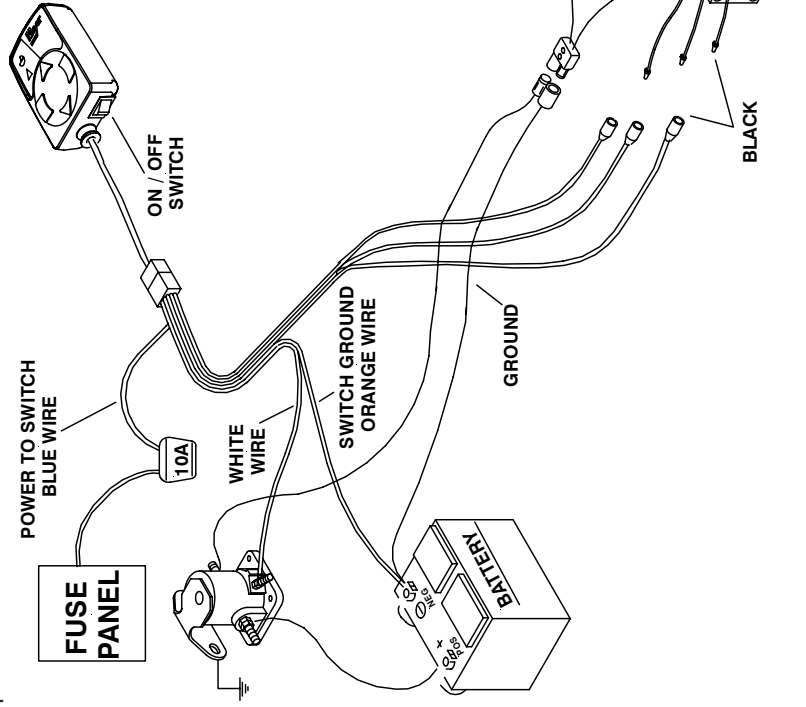

When the DOWN arrow is activated, electric power is sent only to the "A" Solenoid via wiring harness. Electrical power is sent to this solenoid by the BLACK wire. This wire connects to the BLACK wire on the "A" Solenoid. Lowering of the snow plow an inch at a time is possible by tapping the down arrow in short intervals. Holding down the down arrow will activate the float light located on the upper left of the Electro-Touch® control switch. This light indicates the snow plow is now in the Lower / Float position. In this position the snow plow will be able to follow the contour of the road and the snow plow can also be angled left or right. Touching the Up arrow on the touch pad automatically cancels the Lower / Float position. Turning off the ignition switch or the touch pad will reset the switch.

Note: The rate (speed) at which the snow plow is lowered is adjustable. Turning the Lower Adjustment Screw in (clockwise) will decrease the speed at which the plow is lowered by gravity, and turning the screw out (counterclockwise) will increase the rate.

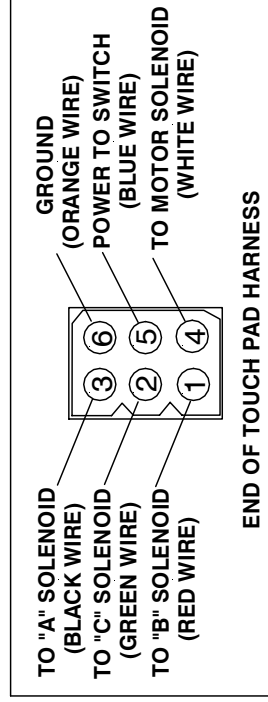

E-60 AND E-60H LOWER / FLOAT

E-60 AND E-60H LOWER / FLOAT FLOW CHART

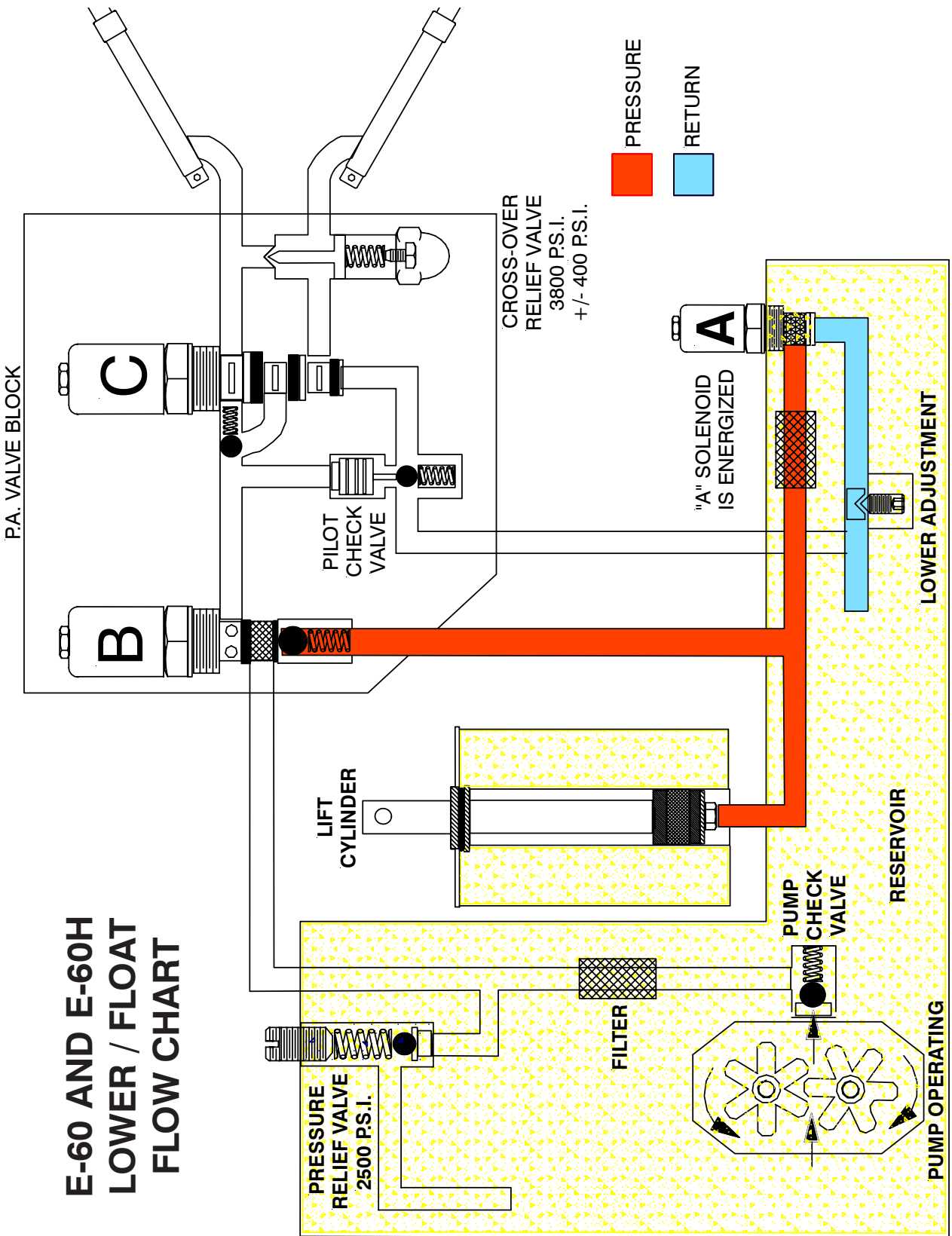

ANGLE LEFT E-60 and E-60H

When the Electro-Touch® control switch is powered up, yellow lights illuminate the location of the individual arrows for the function of the snow plow: Up, Left, Right and Down.

CAUTION:

When the snow plow is not in operation, the Electro-Touch® control switch should be in the "OFF" position.

IMPORTANT:

The power lead (blue wire with fuse) should be connected to a terminal on fuse panel that is **HOT ONLY** when the ignition switch is in the "ON" position.

When the Left arrow is activated, electric power is sent only to the **MOTOR Solenoid** via wiring harness.

MOTOR SOLENOID

Electric power is sent to this solenoid by the **WHITE** wire. This wire connects to the small terminal on the motor solenoid. This wire activates the solenoid switch, allowing electrical power from the vehicle battery to pass through the solenoid to the lift motor via cables.

NOTE: Motor Solenoid must have a good ground to operate properly.

"B" and "C" SOLENOIDS

Electrical power is not sent to either of these solenoids. The "C" Solenoid, when **NOT** energized, directs the pressurized hydraulic fluid out of the hose to the right (passenger-side) power angle cylinder.

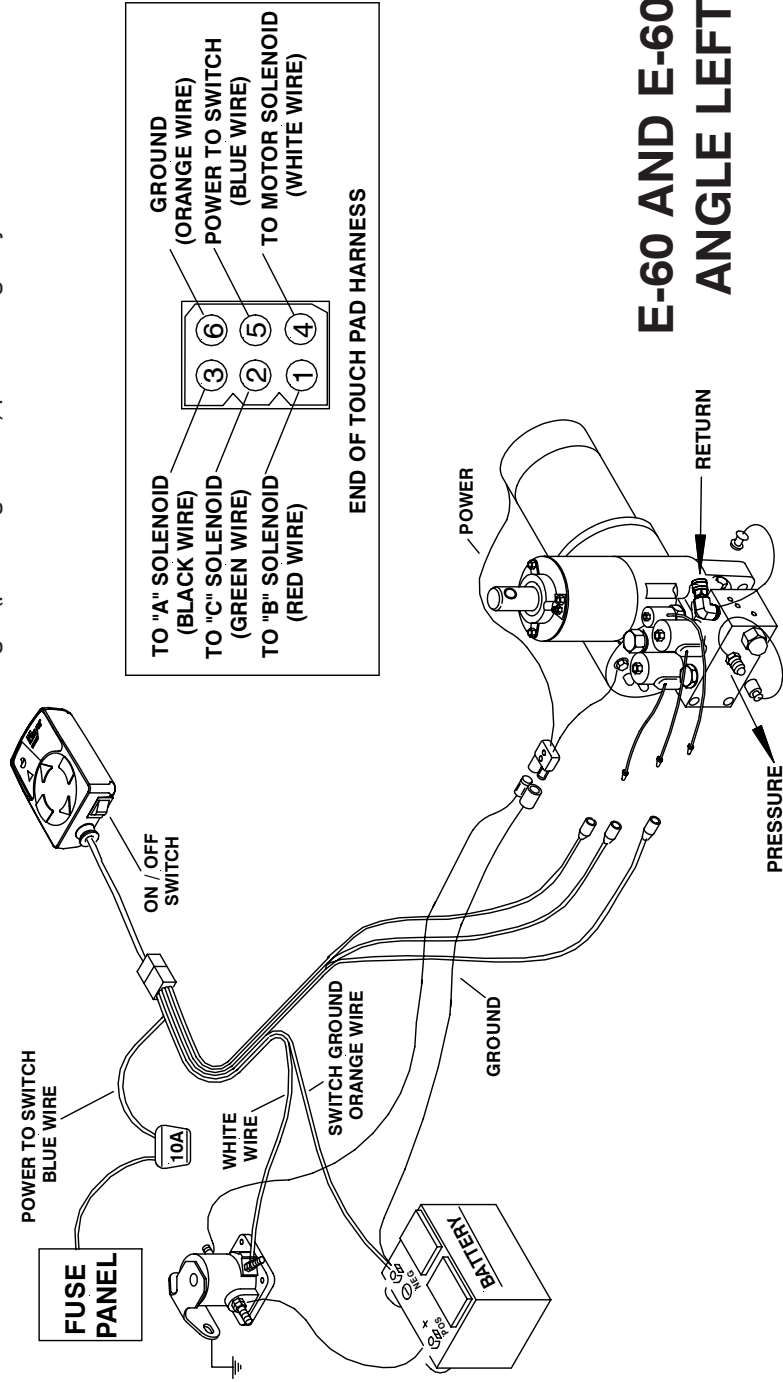

E-60 AND E-60H ANGLE LEFT

E-60 AND E-60H ANGLE LEFT FLOW CHART

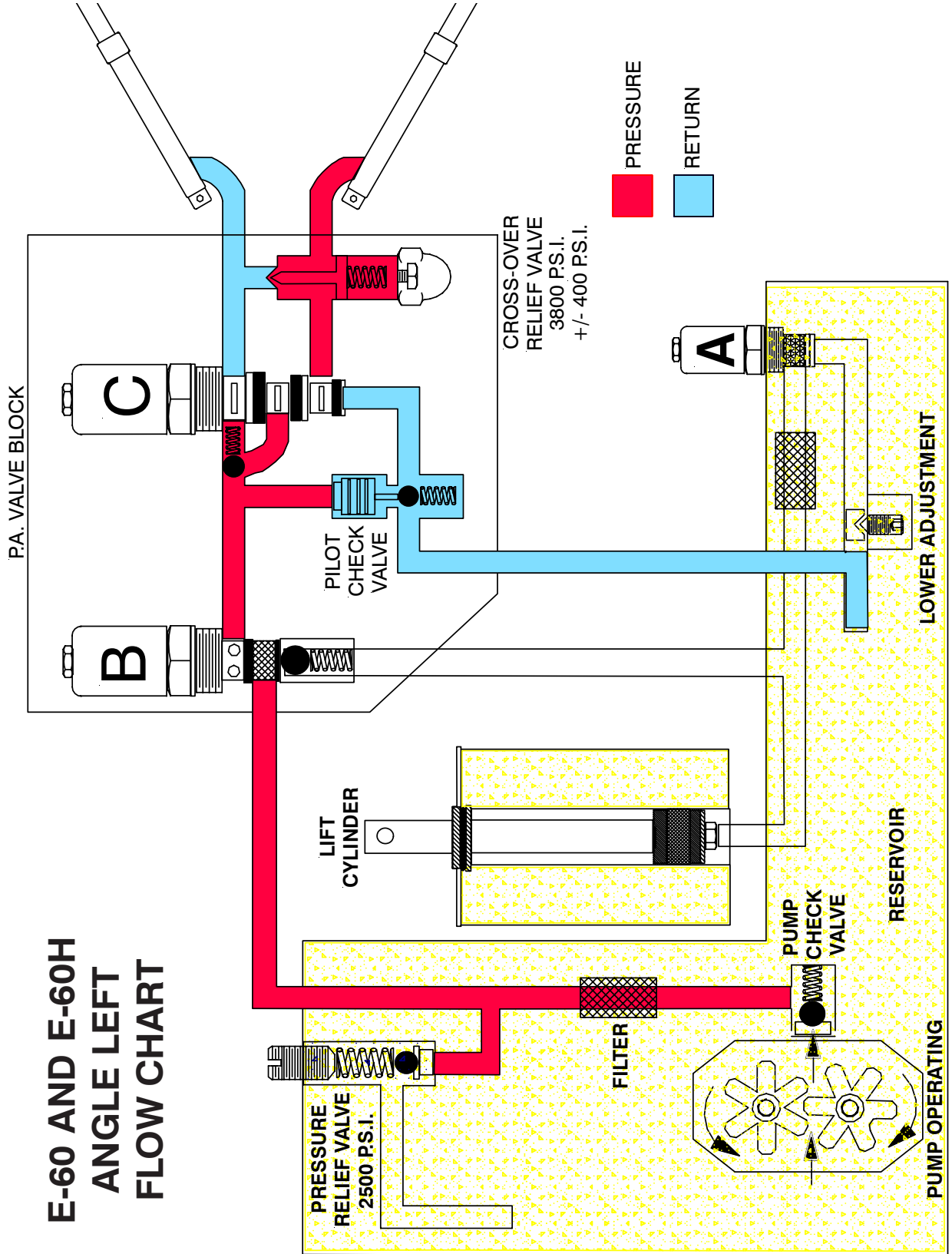

ANGLE RIGHT E-60 and E-60H

When the Electro-Touch® control switch is powered up, yellow lights illuminate the location of the individual arrows for the function of the snow plow: Up, Left, Right and Down.

CAUTION:

When the snow plow is not in operation, the Electro-Touch® control switch should be in the "OFF" position.

IMPORTANT:

The power lead (blue wire with fuse) should be connected to a terminal on fuse panel that is **HOT ONLY** when the ignition switch is in the "ON" position.

When the Right arrow is activated, electric power is sent to the **MOTOR & "C" Solenoid** via wiring harness.

MOTOR SOLENOID

Electric power is sent to this solenoid by the **WHITE** wire. This wire connects to the small terminal on the motor solenoid. This wire activates the solenoid switch, allowing electrical power from the vehicle battery to pass through the solenoid to the lift motor via cables.

NOTE: Motor Solenoid must have a good ground to operate properly.

"C" SOLENOID

Electrical power is sent to this solenoid by the "GREEN" wire. The "C" Solenoid, when energized, directs the pressurized hydraulic fluid out of the coupler to the left (driver-side) power angle cylinder.

Note: See illustration below for proper location of "C" Solenoid on the lift unit.

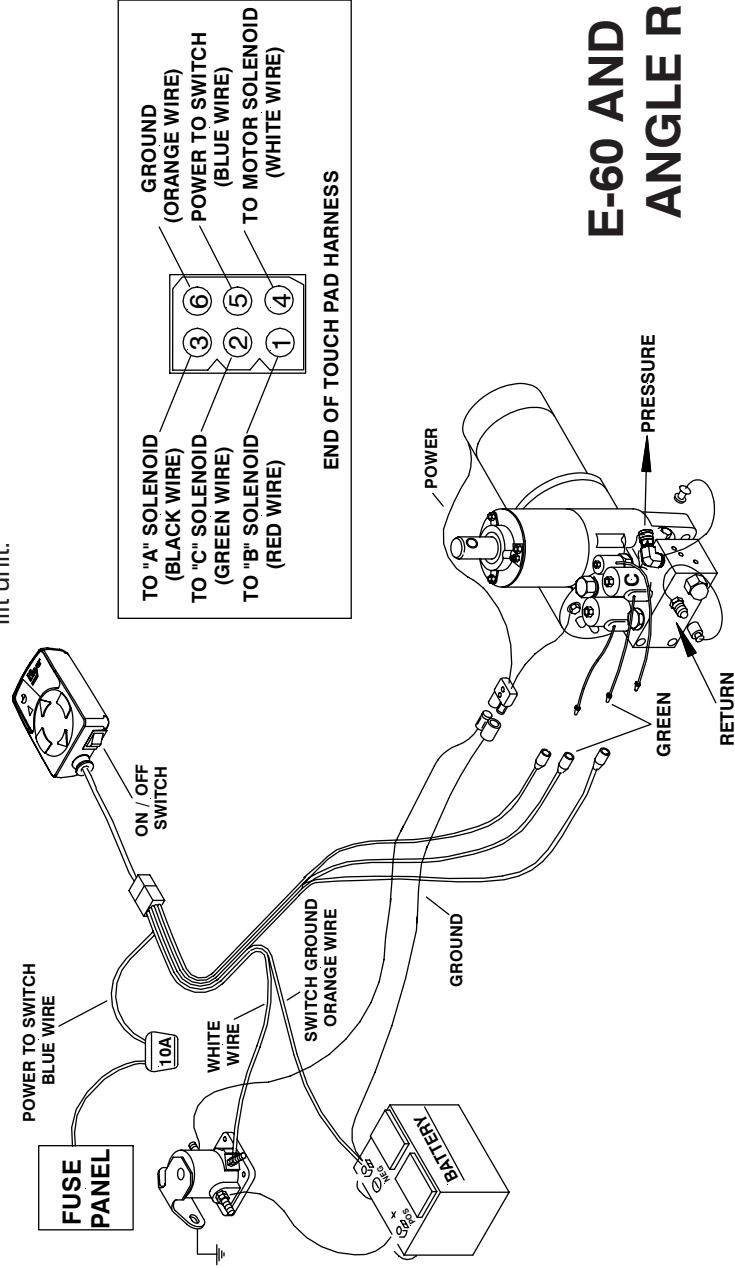

E-60 AND E-60H ANGLE RIGHT

E-60 AND E-60H ANGLE RIGHT FLOW CHART

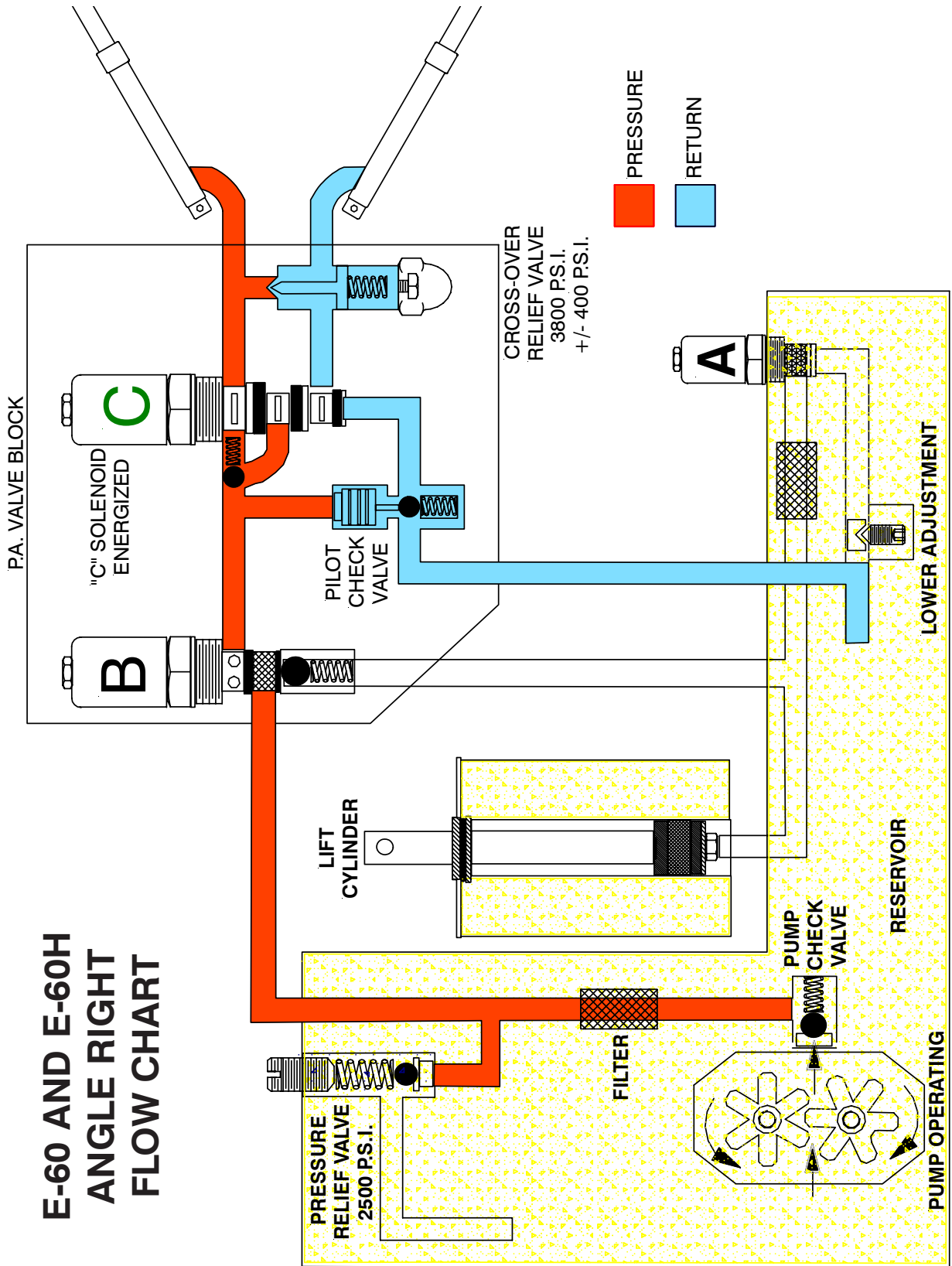

QUIK-LIFT® UNIT COMPONENTS

MOTORS (4-1/2") E-60, E-60H

The 12-volt DC high torque motor used on the Quik-Lift® units are interchangeable among all three models. Its function in all three applications is to drive the hydraulic pump. The motor is only energized and operating when pressurized hydraulic fluid is required.

Two different brand motors were used. While they are interchangeable and have nearly identical performance characteristics, they have distinctive design differences.

Fenner

The Fenner motor is a four pole electro magnet motor which consists primarily of a 4-1/2" diameter solid steel frame (coated to resist corrosion), armature, brushes, field coils and pole pieces. This motor can be used on vehicles with either the common negative ground electrical system or the positive ground electrical system.

Iskra - Single and Two terminal

The Iskra motor is a four pole, electromagnet motor which consists primarily of a 4-1/2" diameter solid steel frame, armature, brushes, field coils and pole pieces. This motor can be used on vehicles with either the common negative ground electrical system or the positive ground electrical system.

HYDRAULIC PUMP

The pump in a hydraulic system employs an external source of power to apply a force to a liquid. A pump develops no power of its own. It simply transfers power from an external source (the electric motor on the Quik-Lift® unit) to the liquid in the hydraulic system.

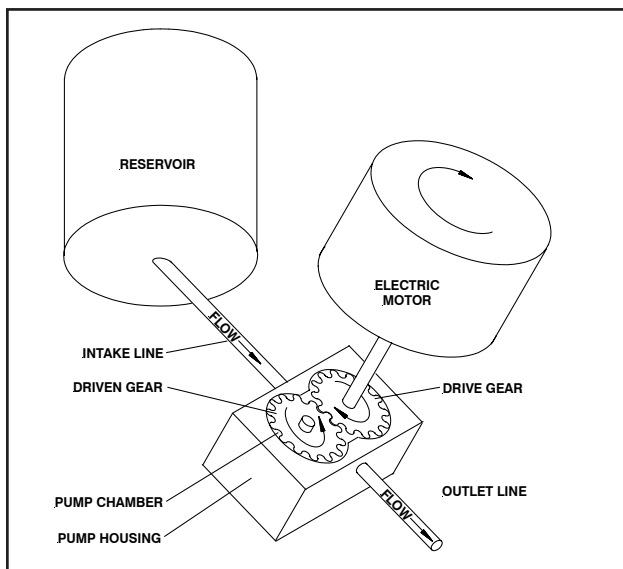

FIGURE 1-1

The basic operating principles of the hydraulic pump used in the Quik-Lift® units are quite simple. Figure 1-1 illustrates the basic components of a positive displacement gear type pump and their functions. The pumping action takes place within the pump chamber which is connected to the reservoir by the intake line. The pump chamber has an outlet line in which the liquid under motion and pressure leaves the pump to perform work.

PRESSURE RELIEF VALVE

A basic pressure relief valve is shown in Figure 1-2. It consists of a poppet valve and a valve spring. Both are located in a passage which connects the inlet passage to the outlet passage. The poppet valve is normally held closed by the valve spring, sealing the connecting passage from the pressurized outlet passage. The poppet valve, being a ball, is exposed to the pressurized hydraulic fluid in the outlet passage. Whenever the hydraulic pressure against the poppet valve becomes greater than the pressure being exerted on the poppet valve from the opposite direction by the valve spring, the poppet valve will open. This allows some of the pressurized hydraulic fluid to flow through the connecting passage to the non pressurized inlet passage. The effect is to lower the pressure in the outlet passage which will allow the valve spring to close the poppet valve again. Under a condition, such as when a hydraulic cylinder is extended to the end of its stroke, eliminating additional space for the pressurized hydraulic oil to be pumped into, the alternate opening and closing of the poppet valve controls the pump's pressure output and provides an escape for the pressurized hydraulic fluid.

The pressure relief valve used in the Quik Lift® pump, while more sophisticated than the one described, functions in the same manner. The pump pressure relief valve may be set by adjusting the set screw after installing a suitable pressure gauge of 3000 P.S.I. in the circuit. **See Specifications on page 53.**

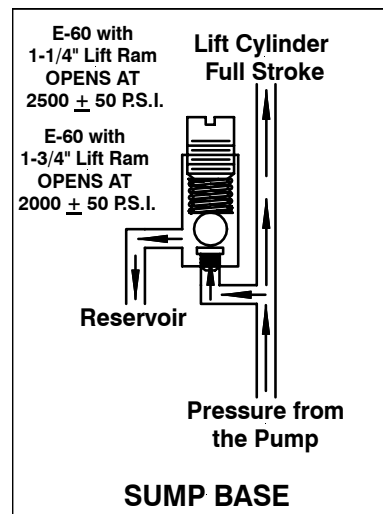

FIGURE 1-2

QUIK-LIFT® UNIT COMPONENTS CONT.

SOLENOID VALVES

Hydraulic valves are simple in concept and all have the same basic function: Control the direction of oil flow. Three types of Solenoid Valve is used on the models E-60, E-60H.

Each Solenoid Valve consists of two components: the Cartridge and the Coil.

Cartridge

The Cartridge consists of the hydraulic valve mechanism and an armature which enables the valve mechanism to be operated and controlled electrically. The Cartridge is designed to screw in and out of the Quik-Lift® units much like the typical “spark plug”.

Coil

The Coil is the electrical component which operates the Cartridge’s valve mechanism by producing magnetism which pulls the Cartridge’s armature toward it. Since the armature is connected to the valve mechanism’s only moving part, it is pulled by the armature.

Figure 1-3 illustrates the typical Coil. Whenever electrical current flows to the Coil, it flows through the winding, which consists of numerous turns of copper wire. The flow of current through the winding produces a magnetic field which pulls the soft iron armature further into the Coil.

The armature pulls the valve spool or poppet valve into its alternate (energized) position. Not illustrated is an integral coil spring, which is compressed when the armature is pulled by the magnetism.

When the current flow ceases, the magnetic field disappears and the compressed coil spring pushes the armature back to its original (de-energized) position.

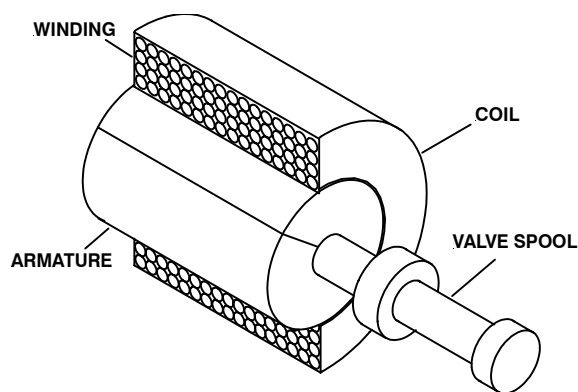

FIGURE 1-3

“A” Solenoid Valve

The “A” Solenoid Valve is used in the E-60 and E-60H. These Cartridges contains a poppet valve whose static or de-energized position is closed. Its energized position is open.

On both models, the “A” Solenoid Valve retains hydraulic fluid in the lift cylinder. It is energized (opened) to allow the hydraulic fluid to flow from the lift cylinder back to the reservoir, enabling the plow to lower by gravity.

The “A” Solenoid Valve is designed to remain energized (open) while the plow is lowered, plowing snow. This is the “float” feature which insures that the plow maintains contact with the ground contour.

“B” Solenoid Valve

The “B” Solenoid Valve is used on the Quik-Lift® models E-60 and E-60H. The “B” Cartridge contains a spool valve whose static (de-energized) position allows the pressurized hydraulic fluid to flow to the “C” Solenoid Valve. In the energized position, the pressurized hydraulic fluid is diverted to the lift cylinder, raising the plow.

“C” Solenoid Valve

The “C” Solenoid valve is used on the Quik-Lift® models E-60 and E-60H. The “C” Cartridge contains a spool valve whose static (de-energized) position allows the pressurized hydraulic fluid to flow to the right power angling cylinder which angles the plow to the left. At the same time, it allows the hydraulic fluid being forced from the retracting left power angling cylinder to flow through the “C” Cartridge back to the reservoir.

In the energized position, the pressurized hydraulic fluid is diverted to the left power angling cylinder, angling the plow to the right. Also, the hydraulic fluid being forced from the retracting right power angling cylinder flows through the “C” Cartridge back to the reservoir.

QUIK-LIFT® UNIT COMPONENTS CONT.

CHECK VALVES

Check valves are very simple devices that have two basic functions: They prevent fluid from passing through them in one direction, but they allow fluid to pass through them in the opposite direction.

In both models a pump check valve is used to prevent hydraulic fluid from leaking back through the pump to the reservoir.

The E-60 and E-60H models incorporate two additional check valves, necessary because the “B” and “C” Solenoid Valves, being spool valves, have some leakage.

One check valve is located between the “B” Solenoid Valve and the lift cylinder. It prevents the hydraulic fluid in the lift cylinder from leaking back through the “B” Solenoid Valve which could cause the weight of the plow to angle the plow to the left by forcing hydraulic fluid through the “C” Solenoid Valve into the right power angling cylinder.

The other check valve is located between the “B” and “C” Solenoid Valves. It prevents the hydraulic fluid in either power angling cylinder from being forced through the “B” Solenoid Valve to the left cylinder.

PILOT CHECK VALVE

The pilot check valve used only on the E-60 and E-60H is more sophisticated in that it incorporates a piston in addition to the ball, seat and spring. It is located between the “C” Solenoid Valve and reservoir. It has two functions: The first is to prevent the hydraulic fluid in either power angling cylinder from leaking back to the reservoir. The second is to allow the hydraulic fluid from the retracting power angling cylinder during the angling cycle to return to the reservoir. This is accomplished by the pressurized hydraulic fluid moving the piston which forces the check ball off its seat.

CROSSOVER RELIEF VALVE

When plowing snow, a snow plow can be exposed to damaging forces caused by impact with hidden obstructions, ends of curbs, etc. With power angling, these damaging forces can damage not only the snow plow but also the vehicle. The crossover relief valve has the function of protecting the snow plow system against these damaging forces under normal snow plowing conditions. The crossover relief valve, cannot protect the system from damaging forces that are too great due to abusive snow plowing conditions.

Basically, the crossover relief valve functions exactly like the previously described pump relief valve. It's designed to open at a specific pressure. In this instance, the pressure is not produced by the pump but rather by the damaging force. As an example, assume that the right corner of the plow runs into the end of a curb. The impact will attempt to collapse the right power angling cylinder. As a result, very high hydraulic pressure is produced within the cylinder. When the produced pressure is high enough, it opens the crossover relief valve, allowing the highly pressurized hydraulic fluid to flow directly to the left power angling cylinder.

When the crossover relief valve functions in this manner, the excessive pressure is released, the excessive energy produced by the impact is absorbed, and the result is only a change in angled position of the plow.

The crossover relief valve may be adjusted to the specified pressure of 3800 P.S.I. \pm 400 by turning the 3/8” hex cap screw after installing a suitable pressure gauge of 5000 P.S.I. in the circuit. **TIGHTEN (TURN IN) ADJUSTMENT SCREW TO INCREASE PRESSURE.** See Disassembly Figure 3-49 thru 3-56. Reassembly figures 3-57 thru 3-69.

QUIK-LIFT® UNIT COMPONENTS CONT.

SWITCHES

Electro-Touch® Control Pad (E-60 and E-60H)

IMPORTANT:

The power lead to the switch should be connected to a terminal on the fuse panel that is HOT ONLY when the ignition switch is in the "ON" position.

When the control switch is powered up, yellow lights illuminate the arrows of the individual functions. The up arrow for raise, the left arrow for angle left, the right arrow for angle right and the down arrow for lower or float.

Holding the down arrow for a full second will activate a light located in the upper left corner of the Electro-Touch® switch. This light indicates the snow plow is now in the float position. In this position the snow plow will be able to follow the contour of the road and the snow plow can also be angled to the left or right. Touching the up arrow will automatically cancel the float position.

This switch is short circuit, open circuit and temperature protected. If any of these conditions exists, the overload light will illuminate. The overload light is located just below the float light in the upper left corner of the Touch Pad. Reset is accomplished by cycling the power to the Touch Pad via the on/off switch located to the left of the cord as it enters the Touch Pad.

CAUTION:

When the snow plow is not in operation, the Electro-Touch® Control Switch should be in the "OFF" position.

SOLENOID SWITCH

The Quik-Lift® motor requires more current or amperage to operate than the vehicle wiring, vehicle ignition switch or Touch Pad have the capacity to handle. The solenoid switch is essentially a heavy duty switch with the capacity to handle the heavy current required by the motor. It is closed electrically by the solenoid to convey the heavy current directly from the vehicle battery via heavy gauge electrical cable. The solenoid, which functions essentially the same as the previously described solenoid valves, receives its low amperage current at the proper times via the wiring harness. This solenoid must be grounded to operate properly.

FILTERS

Cleanliness is perhaps the single most important ingredient in assuring a hydraulic system's reliability. Should the hydraulic fluid become contaminated, malfunction and permanent damage to the hydraulic system may occur. For this reason, all the Quik-Lift® units are equipped with a filter system consisting of:

1. A high pressure filter on the pressure side of the pump.
2. A filter screen between the lift cylinder and "A" Solenoid Valve

With this system, the hydraulic fluid is filtered as it leaves the pump. Because clean hydraulic fluid is most important to insure "A" Solenoid Valve reliability, the hydraulic fluid leaving the lift cylinder is filtered before passing through the "A" Solenoid Valve. The filter screen and high pressure filter are easily removed for periodic cleaning or replacement.

NOTE: Additional filter screens are added to the "A", "B" and "C" Cartridge Valves.

IMPORTANT:

Should the hydraulic fluid become contaminated, it will be necessary to replace all the hydraulic oil in the system. The complete system (hydraulic unit, power angling cylinders and hoses) should be flushed. Flush the system with a non wax (Napthenic) cleaner. If kerosene (Parrafinic) is used to flush the system, the system must be flushed again to remove any kerosene with a (Napthenic) based cleaner that is wax free. Refill hydraulic system with Meyer M-1 oil.

SECTION 2 - DIAGNOSIS

CONTENTS

E-60 and E-60H

GENERAL INFORMATION	19
TESTING TIPS	19
“RAISE” Troubleshooting	20
“LEAK DOWN” Troubleshooting	21
“LOWER” Troubleshooting	21
“ANGLE LEFT” Troubleshooting	22
“ANGLE RIGHT” Troubleshooting	23
“WILL NOT HOLD ANGLE” Troubleshooting	24
“CROSSOVER RELIEF VALVE” Flow Chart.....	24

DIAGNOSTIC FLOW CHART FOR E-60, E-60H QUIK-LIFT® UNITS

These charts are intended to be used as an aid in diagnosing problems on the Quik-Lift® units. They are not a substitute for factory training and experience. Be certain to read the General Information and Testing Tips sections before attempting any troubleshooting.

IMPORTANT: Maintenance and repairs must be performed with the moldboard on the ground.

General Information

Before any troubleshooting is started, make certain the following conditions are met.

1. The moldboard is pointing straight ahead. This can often be done by coupling the left cylinder into the right cylinder and pushing the moldboard by hand.
2. The power angling cylinders must be installed correctly on to the A- frame. The left cylinder (Driver's side) has a hose attached with a male half of a coupler at the end; the right cylinder (Passenger side) has a hose attached with a female half of a coupler at the end.
3. The solenoid coils must be on their proper valve. (See drawing below).

TESTING TIPS

Many tests do not require removing the Quik-Lift® unit from the vehicle. However, more thorough testing can be performed using the Meyer Test Stand which allows direct pressure and amperage readings.

1. Using a screwdriver or other small tool to check for magnetism of the solenoid coils "A", "B" and "C". Place the tool on the nut securing the coil and have an assistant operate the switch. You should feel strong magnetic attraction.
2. Use a test light or volt meter to determine whether there is power at the harness or switch.
3. When determining AMP draw of the motor, always obtain the highest value possible, i.e. at maximum raise or maximum angle with motor running.
4. Proper rotation for the 4-1/2" motor (Fenner/Iskra) is clockwise by looking at the motor shaft from the bottom of the motor.
5. The pump shaft of a good pump can be turned smoothly using two fingers. If it can't be turn easily, the pump is too tight and must be replaced.
6. Pump pressure can be measured at an angle hose (note pressure at full angle) or in the pressure filter port (an adaptor is necessary for the filter port).
7. Flush the complete system including unit, hoses and power angling rams with a non wax (Napthenic) oil / cleaner. If kerosene (Parrafinic) is used to flush the system, the system must be flushed again to remove any kerosene with a (Napthenic) based oil / cleaner that is wax free.

The **current 22154 Electro-Touch Control** has been redesigned. The Touch Pad now has raised buttons and its circuitry has been changed from analog to digital, functions have not changed. For troubleshooting for power at the solenoids do not disconnect wires. To check for power, prick the wire through the insulation for testing. The **Electro-Touch Control** knows when a short or an open connection occurs and will go into overload mode for the function being activated. To reset the Touch Pad turn the switch on and off. The **Electro-Touch Control** will not operate if not wired properly as per the installation instructions (1-690 & 1-759).

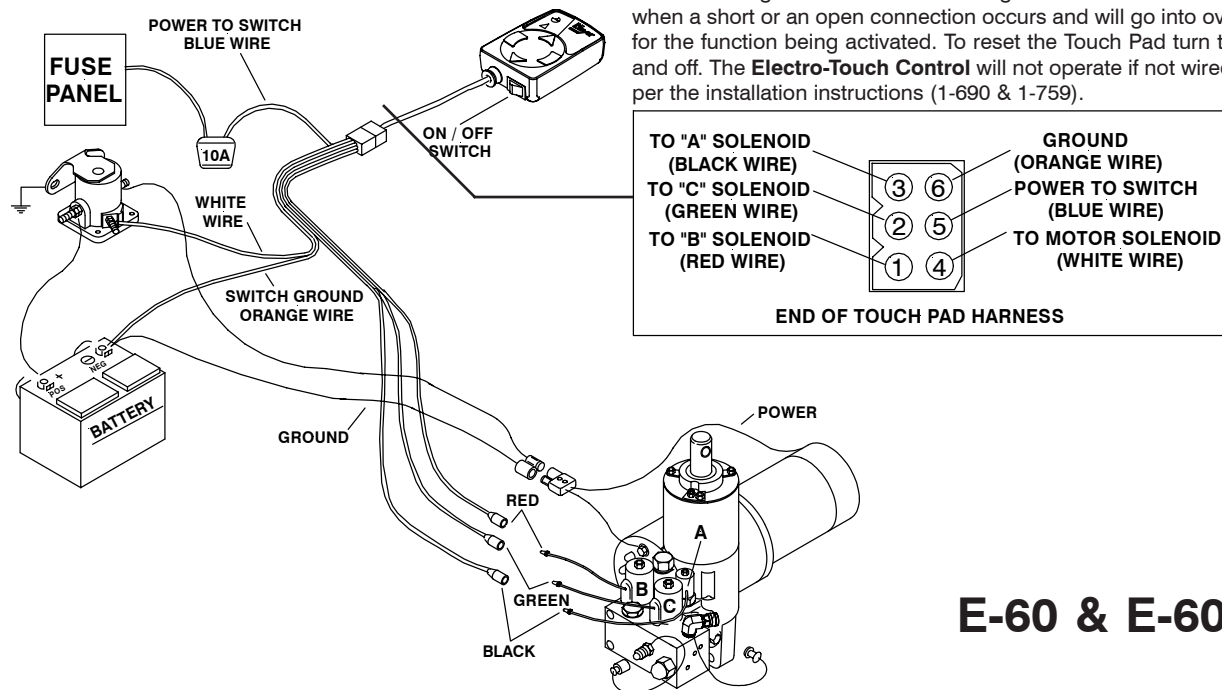

E-60 & E-60H

E-60 AND E-60H

SNOW PLOW WILL NOT RAISE

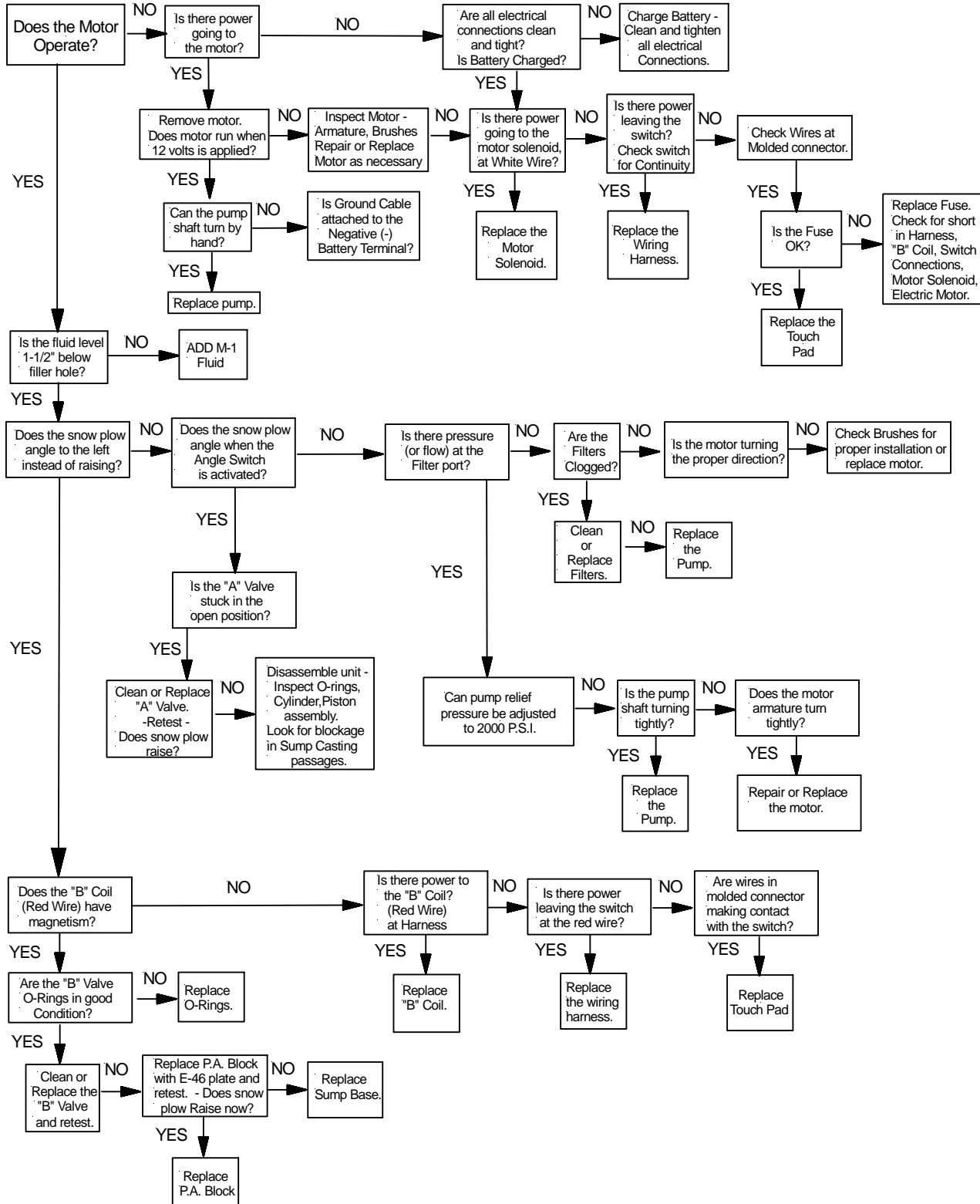

E-60 AND E-60H

SNOW PLOW LEAKS DOWN

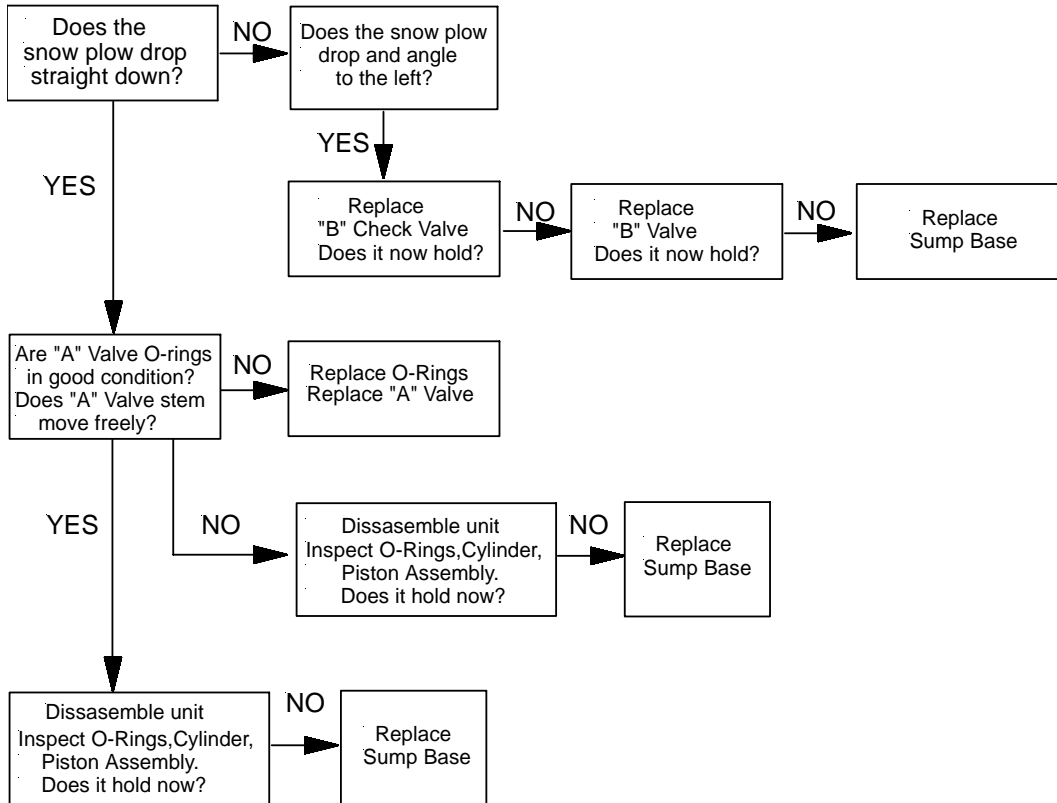

SNOW PLOW WILL NOT LOWER

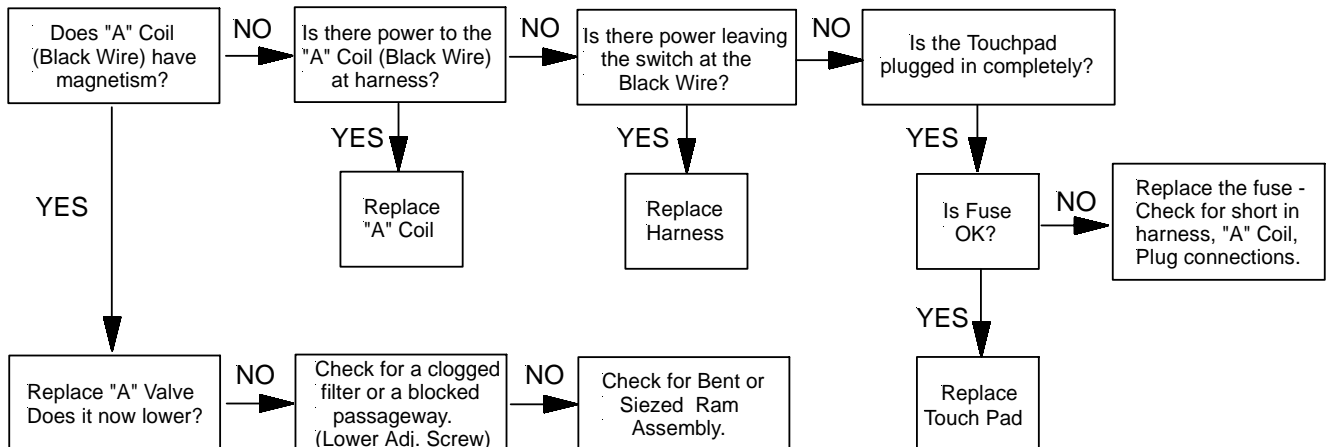

E-60 AND E-60H

SNOW PLOW WILL NOT ANGLE LEFT

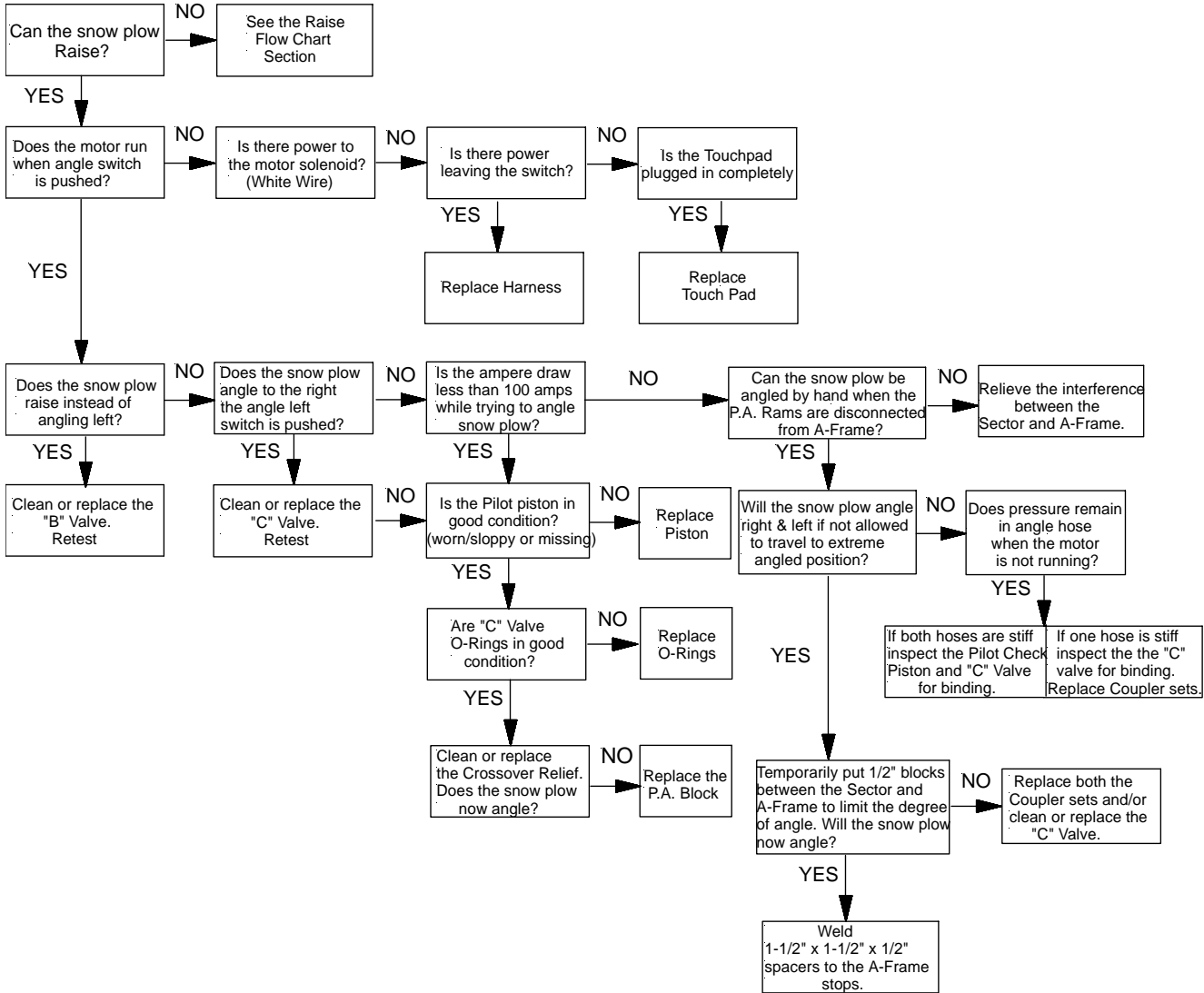

E-60 AND E-60H

SNOW PLOW WILL NOT ANGLE RIGHT

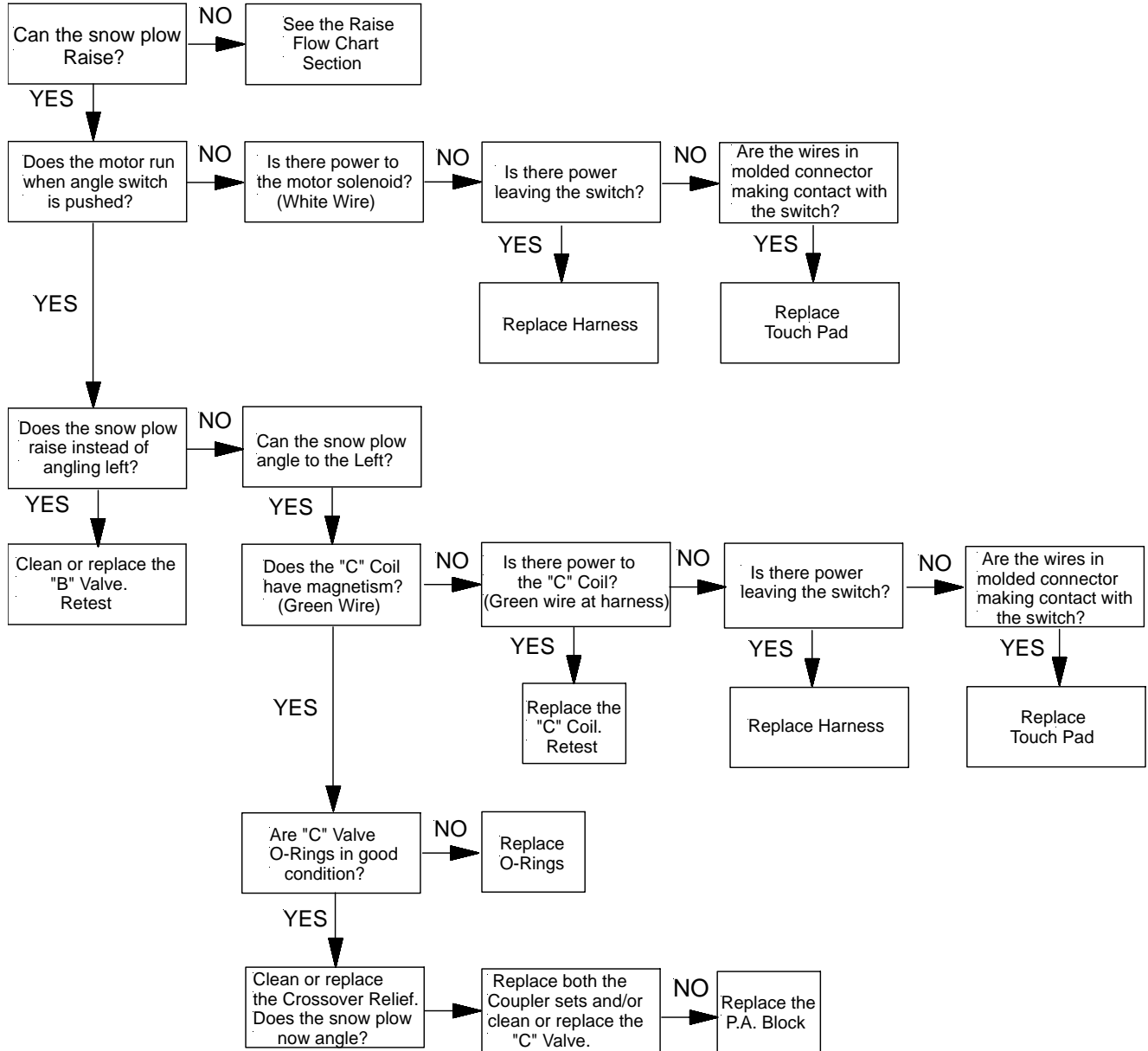

E-60 AND E-60H

SNOW PLOW WILL NOT HOLD ANGLE

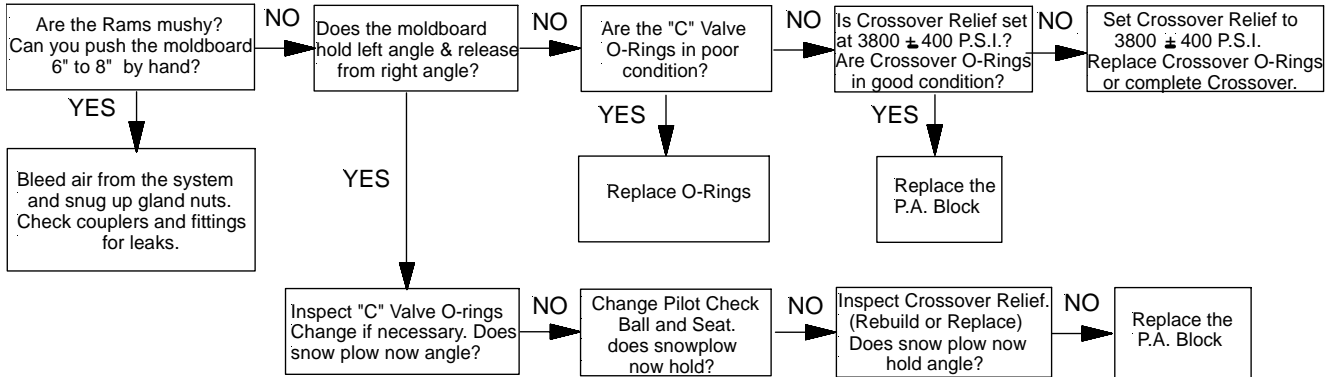

Crossover Relief Valve

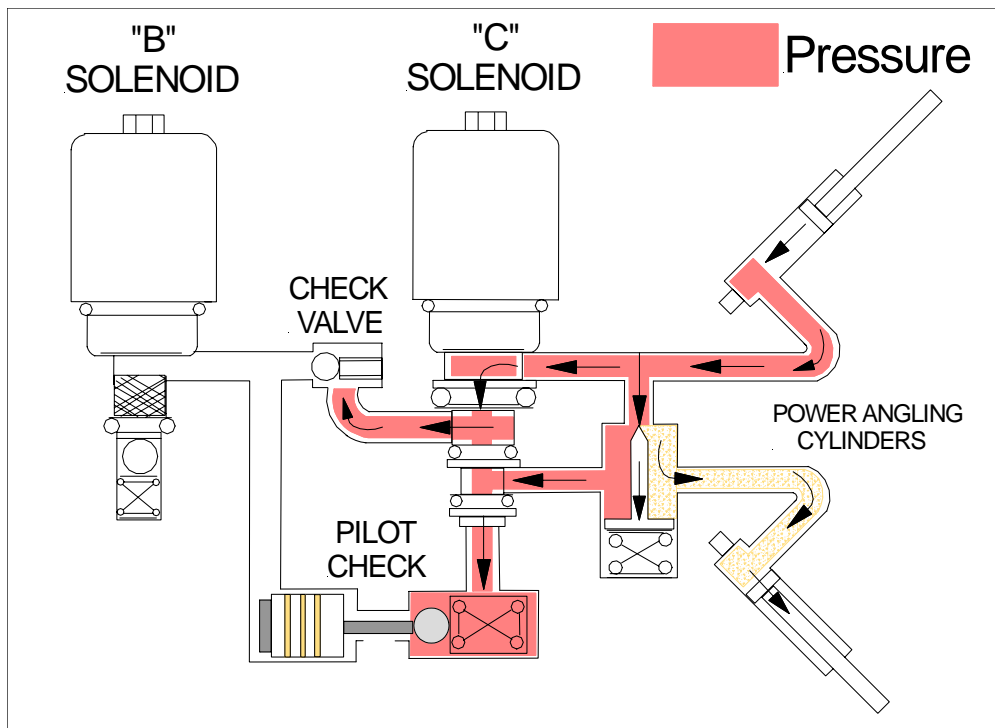

**CROSSOVER
RELIEF
3800 ± 400 P.S.I**

SECTION 3 - REPAIR PROCEDURES

CONTENTS

QIUK-LIFT®	
Parts List	26
Exploded View	27
GENERAL INFORMATION	28
UNIT DISASSEMBLY AND REASSEMBLY	28
Disassembly	28
Photos	29-38
Reassembly	39
• Additional Reassembly Points	28
Photos	39-40
PUMP	28
Shaft Seal Replacement	28
Pump Disassembly	30-31
Pump Reassembly	47-48
CROSSOVER RELIEF VALVE	
Disassembly	41-42
Reassembly	43-46
VALVE CARTRIDGE INFORMATION "A", "B" & "C"	50
"A" Cartridge	50
"B" & "C" Cartridges	50
BRUSH REPLACEMENT	51
Iskra Brush Replacement	51
Fenner Brush Replacement	51
SPECIAL TOOLS	52
SPECIFICATIONS	53

PARTS & INSTALLATION INSTRUCTIONS

E-60 & E-60H QUIK LIFT®

PARTS LIST

ITEM	STANDARD- UP THROUGH	LONG STROKE- MDII	QTY.	DESCRIPTION	ITEM	STANDARD- UP THROUGH	LONG STROKE- MDII	QTY.	DESCRIPTION
	C-9 1-1/8" x 6" Stroke E-60	HM-9 & HM-10 1-1/8" x 8" Stroke E-60H				C-9 1-1/8" x 6" Stroke E-60	HM-9 & HM-10 1-1/8" x 8" Stroke E-60H		
1	15726	15726	1	Base & Tank Assembly	53a	15972	15972	1	• "A" Solenoid Assembly
2	15706		1	• Sump Base	54a	15905	15905	1	•• "A" Coil, Black Wire
2	15335	15336	1	• Ram Assy. SEE ILLUSTRATION	55a	15660	15660	1	•• "A" Cartridge Valve
3	15208	15206	1	• Ram Assembly 1-3/4"	56	22435	22435	1	•• "A" Coil Nut
4	15158	15158	1	•• Ram	*	15431	15431	1	•• Seal Kit, "A" Valve
5	15219	15219	1	•• Piston	57	15758	15758	1	• VALVE ASSY w/COUP
6*	15162	15162	1	•• Piston Follower	58	22295	22295	1	•• Forged 90 Degree Elbow
7*	15125	15125	1	•• Packing Cup	59	22293	22293	1	•• Coupler, Male Half Low Spill
8		15760	1	•• O-ring 7/16" I.D.	60	22294	22294	1	•• Coupler, Female Half Low Spill
9	20316	20316	1	•• Spacer	61	15606	15606	1	• Kit-Crossover Valve
10	15738	15738	1	• Locknut 1/2-13	62			1	•• O-ring
11*	05119	05119	1	• Cover & Seal Assembly	63			1	•• O-ring
12*	15131	15131	1	•• Wiper	64			1	•• Cage
13	15737	15737	1	•• O-ring 3-1/2" I.D.	65			1	•• O-ring w/Glyd. Ring
14	08473	08473	1	•• Sleeve	66			1	•• Poppet
15	21805	21805	1	• Pressure Relief Valve Kit	67			1	•• Washer
16	15696	15704	1	•• Reducer Bushing 1/4-1/8	68			1	•• Guide
17	15953	15205	1	•• Pressure Relief Valve	69			1	•• Spring
18	15209	15209	1	• Cylinder Tank	70			1	•• Spacer
19*	15198	15198	1	• Cylinder	71			1	•• Disc
20*	15131	15131	1	• Washer	72			1	•• Plug
21a*	15693		1	• O-ring 1-1/8 I.D.	73			1	•• Adj. Screw
21b*		15163	1	• O-ring 3-1/2 I.D.	74			1	•• O-ring
22	20697	20697	3	• O-ring 1-1/2 I.D.	75			1	•• Acorn Nut 9/16-18
23	15708	15709	3	• O-ring 1-15/16 I.D.	*	15610	15610	1	•• Seal Kit-Crossover Valve
24*	21929	21929	5	• Locknut 5/16-24	76	15639	15639	1	(includes items 62,63,65,74)
25	22129	22129	1	• Stud	77			1	• Kit-Pilot Check Valve
26	15641	15641	2	• Washer, Nyltite 5/16	78			1	•• Ball, Steel
27	15619	15619	1	• Plug w/O-ring 9/16"	79			1	•• Spring
28	21999	21999	1	• Filter	80	15609	15609	1	•• Plug
29	15695		1	•• Plug w/O-ring 9/16"	81	15359	15359	1	• Piston
30	15729	15729	1	• Spacer Ring	82*	15126	15126	1	• Plug Valve Block
31	15688	15688	2	• Pump	83	15697	15697	1	•• O-ring 9/16 I.D.
32	15713	15713	1	• Dowel Pins	84	15382	15382	1	• "B" Solenoid Assembly
33	15574	15574	1	• Locator	85	15698	15698	1	•• "B" Coil, Red Wire
34*	15124	15124	1	• Pump Check Valve	*	15432	15432	1	•• "B" Cartridge Valve
35	15354	15354	1	•• O-ring 3/8 I.D.	86	15358	15358	1	••• Seal Kit-"B" Cartridge
36	15603	15603	1	•• Seat	87	15430	15430	1	• "C" Solenoid Assembly
37	15604	15604	1	•• Ball 9/32	88	15381	15381	1	•• "C" Coil, Green Wire
38*	15700	15700	1	•• Spring	*	15433	15433	1	•• "C"-Cartridge Valve
39	15702	15702	1	• O-ring 3/8 I.D.	89	15576	15576	1	••• Seal Kit-"C" Cartridge
40	15699	15699	1	• Ball Seat	90			1	• Kit-"B" Solenoid Check Valve
41*	15701	15701	1	• Relief Valve	91			1	•• Ball, 7/16
42	22118	22118	1	• O-ring "Special"	92	21826	21826	4	•• Spring
43	15703	15703	1	• Socket Set Screw					• Scr., Soc. Head 5/16-18 x 1-1/2"
44	22119	22119	2	• Pump Mounting Plate					
45	21083	21083	2	• Bolt 3/8-16 x 3-1/4" Gr. 5					
46*	15122	15122	2	• Star Washer 3/8					
47a*	15123	15123	1	• O-ring 1/4 I.D.					
47b*	15124	15124	1	• O-ring 5/16 I.D.					
48	15841	15841	1	• O-ring 3/8 I.D.					
49a	15730	15730	1	• Motor - Two Terminal					
49b	15831	15831	1	• Cover/Motor Mount					
50	22120	22120	2	• Cover/Motor Mount w/tabs					
51	15686	15686	1	• Cap Screw 5/16 x 3-1/4"					
52*	15687	15687	1	• Pump Shaft Seal					
53	15661	15661	1	• O-ring 4-3/4 I.D.					
54	15659	15659	1	• "A" Solenoid Assembly					
55	15660	15660	1	•• "A" Coil, Black Wire					
*	15431	15431	1	•• "A" Cartridge Valve					
			1	•• Seal Kit, "A" Valve					

NOTES:

Parts indented are included in assembly under which they are indented.

- * Parts included in Master Seal Kit Part No. 15705.
- Basic Seal Kit Part No. 15707.
- Set Crossover Relief Valve @ 3800 ± 400 P.S.I. @ 2-1/2 G.P.M.

E-60 with (1-1/4" Lift Ram Assembly)

Set Pump Relief Valve @ 2500 ± 50 P.S.I. full flow @ 1.85 G.P.M.

E-60 & E-60H with (1-3/4" Lift Ram Assembly)

Set Pump Relief Valve @ 2000 ± 50 P.S.I. full flow @ 1.85 G.P.M.

QUIK-LIFT® E-60 and E-60H Exploded View

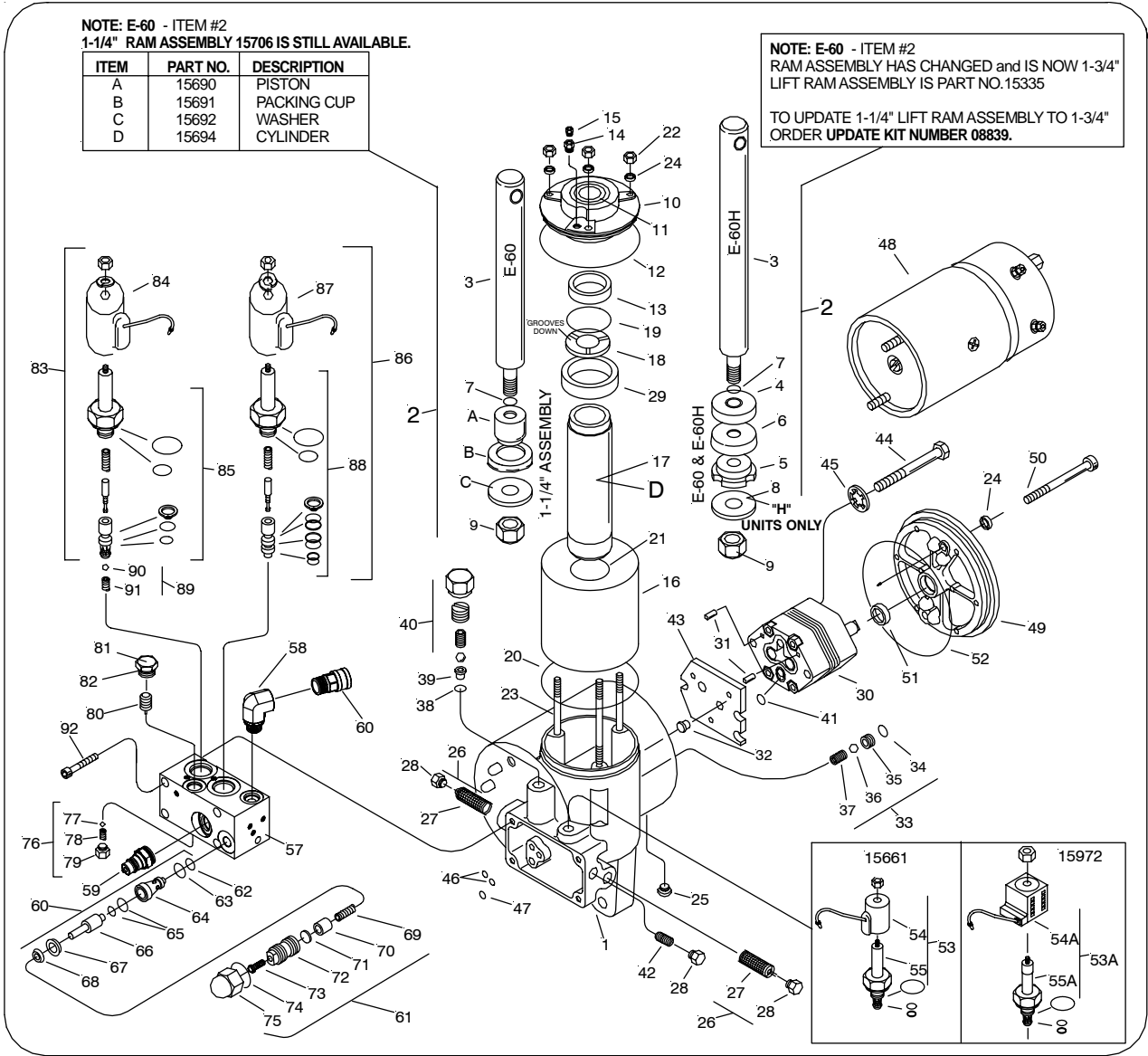

Figure 1A

GENERAL INFORMATION

Using the proper guidelines and precautions, the Quik-Lift® unit is easy to disassemble and reassemble. See Page 27-28 for an exploded view which applies to the E-60 and E-60H models. It should be used as the primary reference for proper reassembly. Where necessary, this section includes additional information, photographs and illustrations to assure proper and efficient repairs.

UNIT DISASSEMBLY AND REASSEMBLY

Model E-60, E-60H units with the exception of the Power Angling Valve Assembly, the parts and disassembly / reassembly procedures are common to all models.

Many repair procedures, including removal and replacement of all Solenoid Valves, can be accomplished without removing the unit from the vehicle. While Figures 3-2 through 3-85 show the unit clamped in a vise, make all possible repairs on the vehicle when possible.

NOTE: Pump Assembly should not be disassembled since it cannot be serviced.

Motor should be taken to the appropriate Fenner/Iskra authorized service station in your area for all parts and service with the exception of brush replacement. Procedure for Fenner/Iskra motor brush replacement is covered separately in this section.

Disassembly

See Figures 3-2 through 3-41 (pages 29-38) for important disassembly points on both models.

See Figures 3-49 through 3-56 (Pages 41-42) for Crossover Relief disassembly.

Reassembly

See Figures 3-42 through 3-48 (pages 39-40), and Figures 3-70 through 3-84 (pages 46-50) for important reassembly points both models.

See Figures 3-57 through 3-69 (Pages 43-46) for Crossover Relief reassembly.

See Figures 3-85 (Pages 50) for Crossover Relief Settings.

See Figures 3-83 (Pages 49) for Drain Plug assembly.

ADDITIONAL REASSEMBLY POINTS

- O-Rings- Coat liberally with hydraulic fluid and position carefully to minimize possibility of damage during assembly.
- Fasteners- Torque all fasteners which are specified to insure proper reliability and prevent damage due to over-tightening.

PUMP

Shaft Seal Replacement

1. Remove motor as shown in Figures 3-3 through 3-6 (pages 29-30).
2. Remove motor mounting plate as shown in Figures 3-7 and 3-8 (page 30).
3. Using a 1/2" deep well socket punch out the original shaft seal, being careful not to damage the motor mounting plate.
4. Liberally coat the replacement seal I.D. with hydraulic fluid.
5. Carefully place the replacement seal spring side up into the motor mounting plate until it is squarely against the casting.
6. Square a block of wood over the seal and use it and a plastic or leather mallet to squarely drive the seal into the motor mounting plate.
7. Replace the motor as shown in Figures 3-80 through 3-82 (page 49).

DISASSEMBLY -ALL MODELS

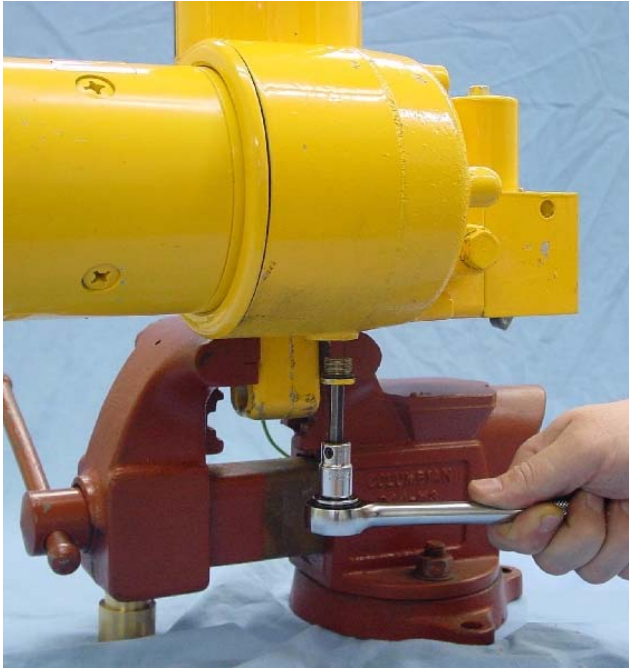

FIGURE 3-2

To drain oil from the unit, remove the drain plug using a 1/4" Allen wrench also remove pressure relief valve.



FIGURE 3-3

To remove motor, first remove the two phillip head screws from the motor end cover. **For brush replacement see Figures 3-87 and 3-88 (page 52).**



FIGURE 3-4

To replace the motor remove the two cap screws, use a 3/8" hex socket on the Fenner motor.

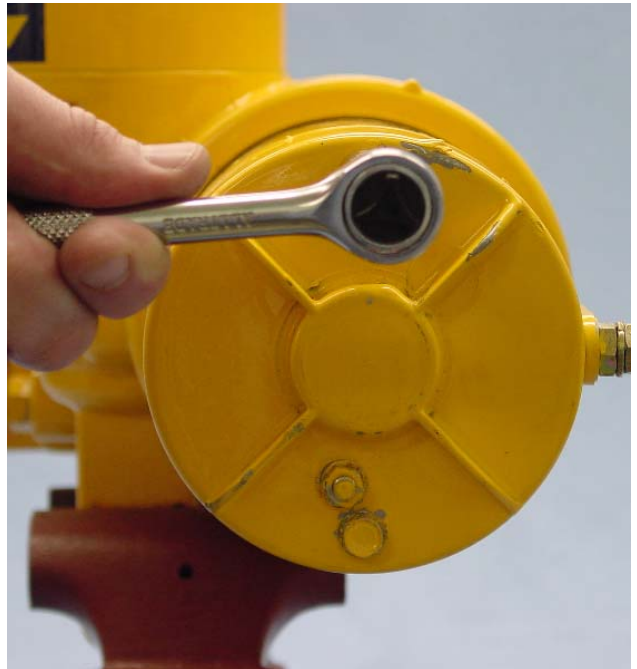

FIGURE 3-5

To replace the motor remove the two cap screws, use a 10mm hex socket on the Iskra motor. **For brush replacement see Figures 3-86 (page 52).**

DISASSEMBLY - ALL MODELS



FIGURE 3-6

Hold the motor parts together while removing it from the pump.



FIGURE 3-7

Remove the two 5/16 x 3-1/4" Cap screws and Nylite washers using a 1/4" Allen wrench.



FIGURE 3-8

Remove Motor Mounting Plate from Sump Base using a large screwdriver and mallet, tapping lightly around the cover.



FIGURE 3-9

Using a 9/16" hex socket, remove the two 3/8 x 3-1/4" bolts and Starwashers that hold the pump in place.

DISASSEMBLY - ALL MODELS



FIGURE 3-10
Remove Pump Mounting Plate.



FIGURE 3-11
Remove Pump Mounting Plate Locator Pin.



FIGURE 3-12
Remove Pump Check Valve.



FIGURE 3-13
There are two filters located within the E-60 and E-60H units. Remove Lower Filter Cap Nut using a 11/16" hex socket.

DISASSEMBLY - ALL MODELS

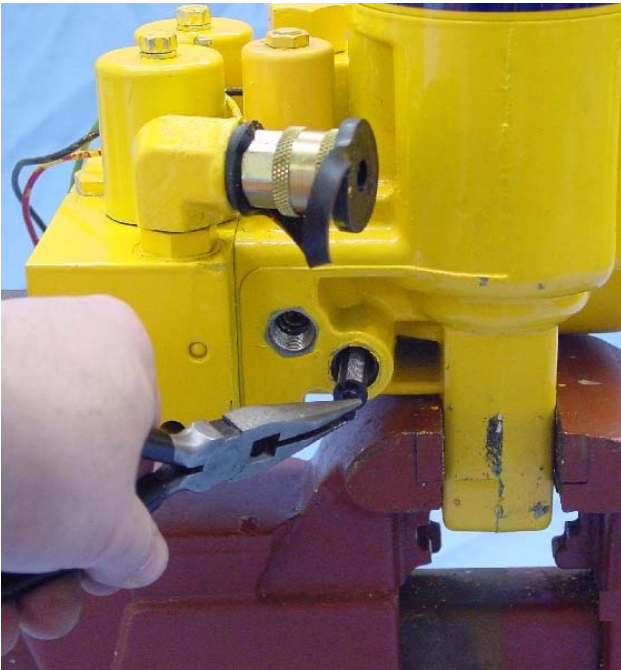

FIGURE 3-14
Remove Lower Filter and clean before reassembly.



FIGURE 3-15
Remove the Lower Adjusting Screw Cap Nut using a 11/16" hex socket.



FIGURE 3-16
Directly beneath the Cap Nut is the location of the Lower Adjustment Screw. Remove the Lower Adjustment Screw from the Sump Base using a 3/16" Allen wrench.



FIGURE 3-17
Remove Pressure Port Filter Cap Nut.

DISASSEMBLY - ALL MODELS



FIGURE 3-18

Remove Pressure Port Filter and clean before reassembly.



FIGURE 3-19

Use a 1/2" Hex Socket remove retaining nut and then remove "A" Coil from "A" Cartridge.



FIGURE 3-20

Remove "A" Cartridge using a 7/8" hex head deep well socket.



FIGURE 3-21

Remove "A" Cartridge from Sump Base.

DISASSEMBLY - ALL MODELS



FIGURE 3-22

Remove Pressure Relief Cap Nut using a 1" hex socket.



FIGURE 3-23

Remove Pressure Relief Adjusting Screw, Pressure Spring, Ball and Ball Seat from Sump Base. To Remove Ball Seat from Sump Base use a 3/16" Allen wrench.



FIGURE 3-24

Use a 7/16" Hex Socket remove retaining nuts and then remove "B" and "C" Coils from their Cartridges.



FIGURE 3-25

Remove "B" Cartridge using a 1-1/4" hex head deep well socket.

DISASSEMBLY - ALL MODELS



FIGURE 3-26
Remove "B" Cartridge from Sump Base.



FIGURE 3-27
A magnetic probe is useful for removal of small parts. Remove the 7/16" Ball located directly beneath the "B" Cartridge



FIGURE 3-28
Remove "B" Check Valve Spring from Valve Body.



FIGURE 3-29
Remove "C" Cartridge using a 1-1/4" hex head deep well socket.

DISASSEMBLY - ALL MODELS



FIGURE 3-30
Remove "C" Cartridge from Sump Base.



FIGURE 3-31
Use a 13/16" hex socket to remove Pilot Valve Plug.



FIGURE 3-32
Pilot Check Piston being removed. Handle Piston with care. If Piston is scratched or damaged, it must be replaced.



FIGURE 3-33
The Valve Body can be removed from Sump Base using a 1/4" Allen wrench.

DISASSEMBLY - ALL MODELS

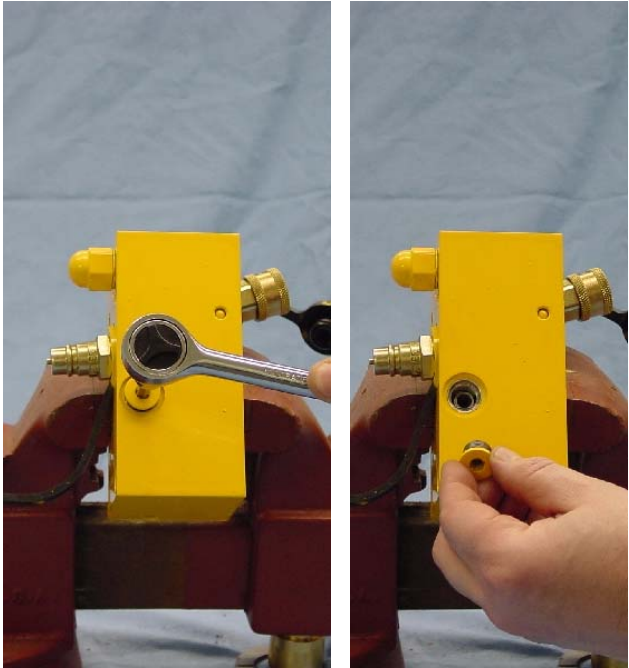

FIGURE 3-34

Use a 1/4" Allen wrench to remove Pilot Valve Plug.

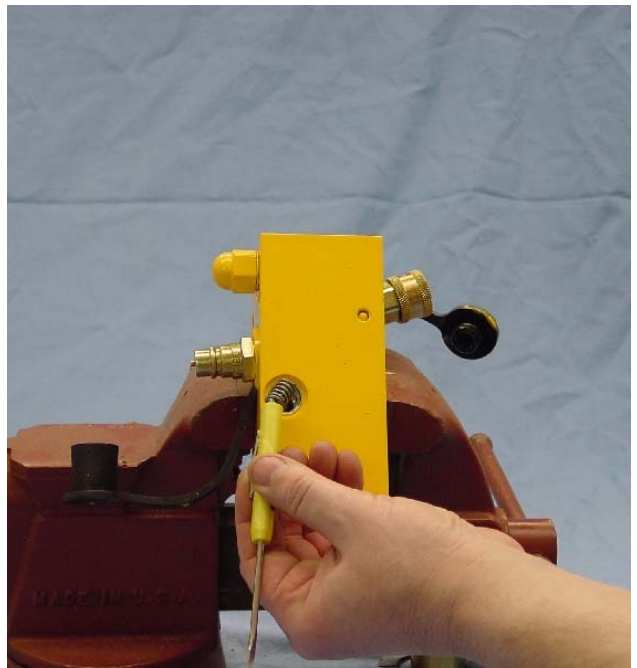

FIGURE 3-35

Pilot Check Spring being removed from Valve Body.

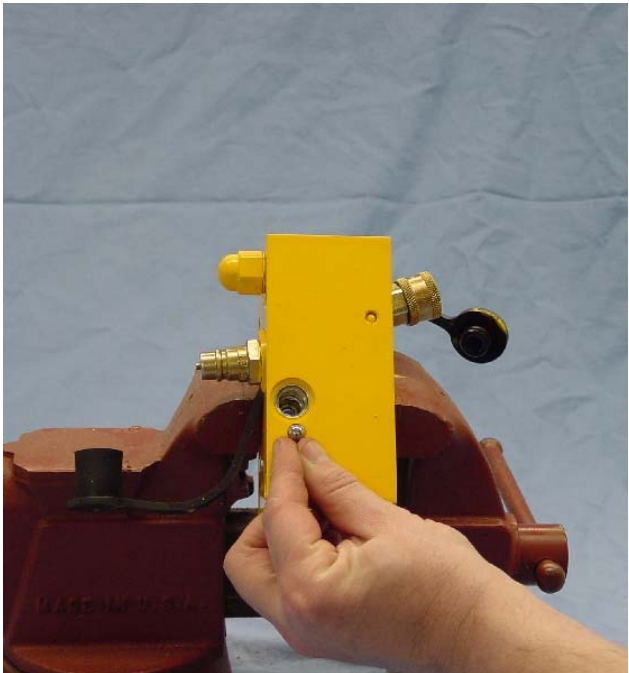

FIGURE 3-36

Pilot Check Ball being removed. This is a 3/8" diameter steel ball.



FIGURE 3-37

Before removing Ram and Piston Assembly, extend rod fully. This drains out remaining oil in Cylinder.

DISASSEMBLY - ALL MODELS



FIGURE 3-38

To remove the Top Cap Assembly, use a 1/2" hex socket to remove locknuts. The Studs usually unscrew from the Sump Base with the locknuts.



FIGURE 3-39

Top Cap cover is removed from Reservoir using a large screwdriver and mallet as shown, tapping lightly around the Top Cap.



FIGURE 3-40

Remove Ram and Cylinder Assembly from Reservoir, then pull Ram out of Cylinder. Worn Packing Cup on Piston should be replaced.



FIGURE 3-41

Remove Cylinder Tank from Sump Base.

REASSEMBLY ALL MODELS

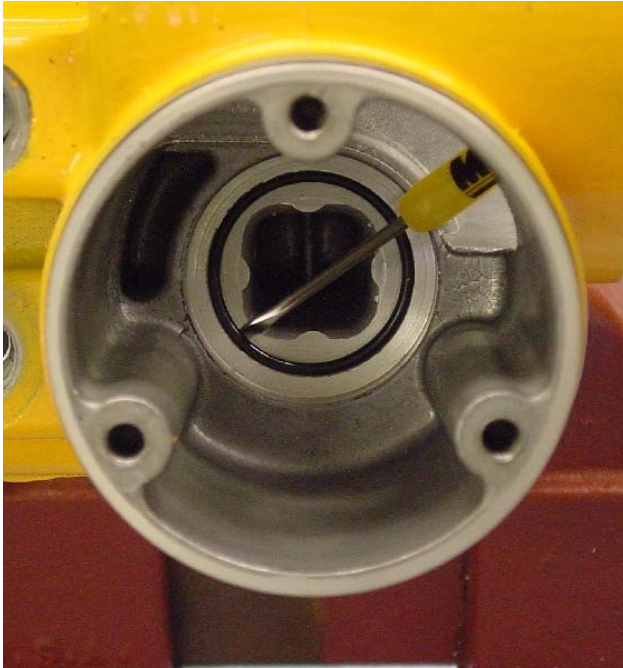

FIGURE 3-42

Remove Lift Cylinder O-ring located in bottom of Sump Base. Note E-60 uses a 1-1/2" diameter O-ring and the E-60H, uses a 1-15/16" O-ring.

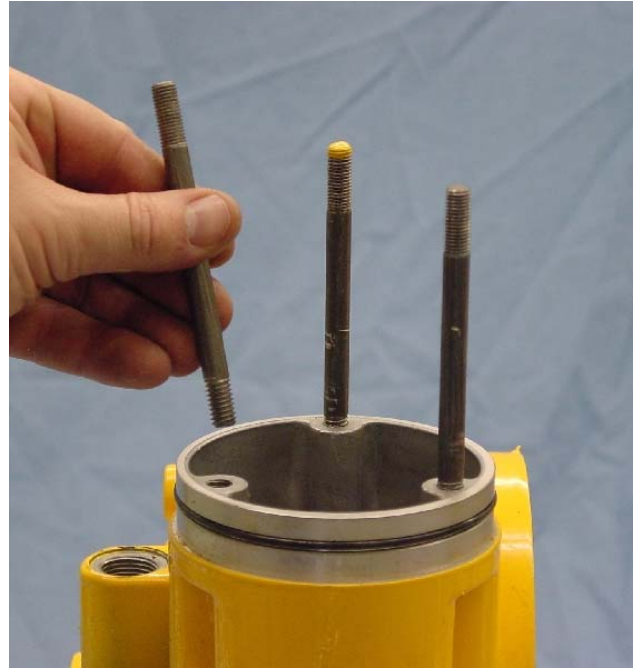

FIGURE 3-43

Remove Locknuts and Nylite washers from Studs. Screw Studs (coarse thread) into Sump Base



FIGURE 3-44

Clean all paint from Ram. Then slide Cylinder over the Ram Piston Assembly using a rubber or leather mallet.



FIGURE 3-45

Install O-ring in bottom of Sump Base. Install Lift Cylinder Assembly making sure it seats squarely on the O-ring.

REASSEMBLY - ALL MODELS



FIGURE 3-46

Install Washer, with the notches facing downward, and install Top Cap Seal.



FIGURE 3-47

Reinstall Reservoir using a mallet to seat Reservoir squarely.



FIGURE 3-48

Install Top Cap Assembly using mallet to seat Top Cap, making certain that the Pressure Relief Valve Assembly is properly located.

CROSSOVER RELIEF VALVE DISASSEMBLY - ALL MODELS

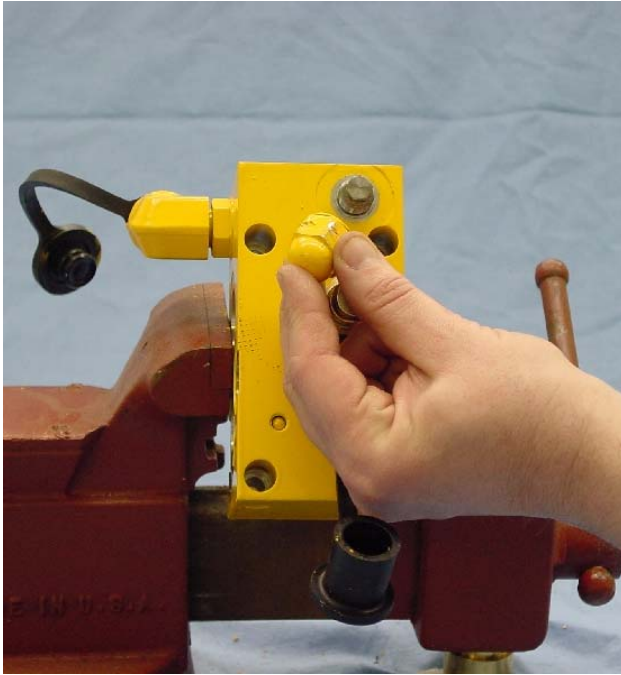

FIGURE 3-49

Remove Acorn Nut and O-ring using a 15/16" open end wrench.

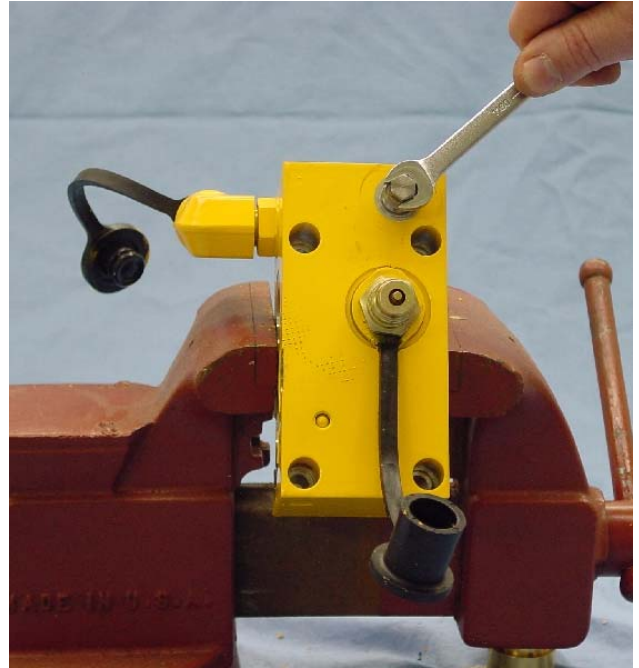

FIGURE 3-50

Remove Plug and Adjusting Screw using a 3/8" open end wrench.



FIGURE 3-51

Remove Plug, Adjusting Screw and Disc.

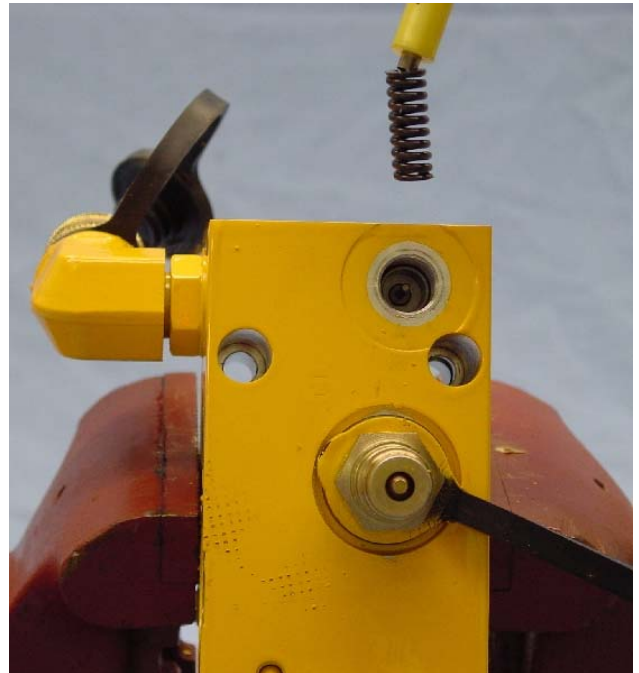

FIGURE 3-52

Remove Pressure Spring.

CROSSOVER RELIEF VALVE DISASSEMBLY - ALL MODELS

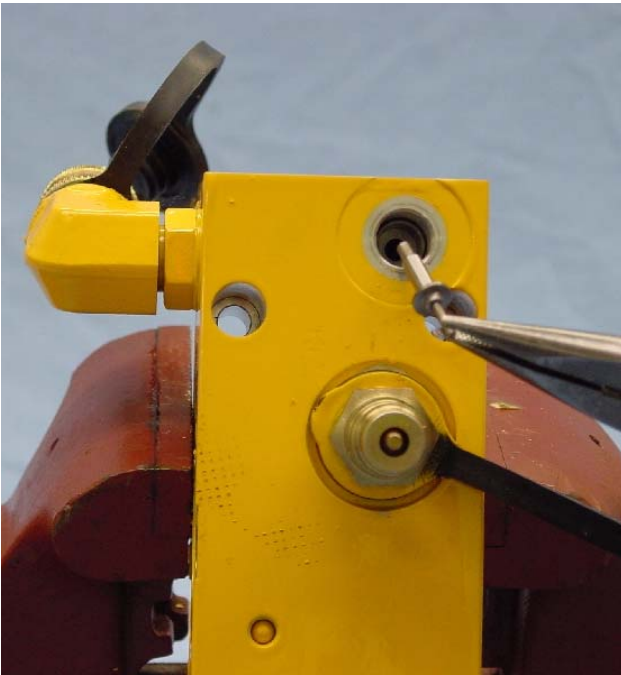

FIGURE 3-53
Remove Poppet, Guide, Washer and Spacer.

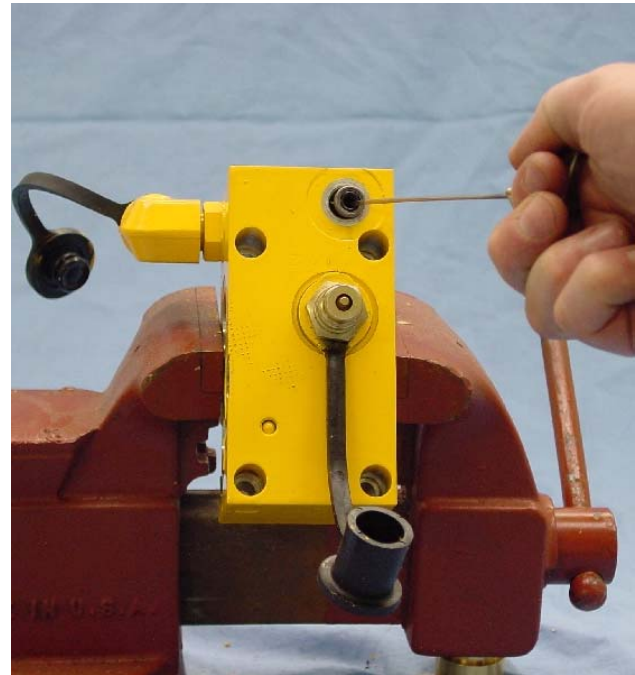

FIGURE 3-54
Remove Cage and O-ring using Special Tool.

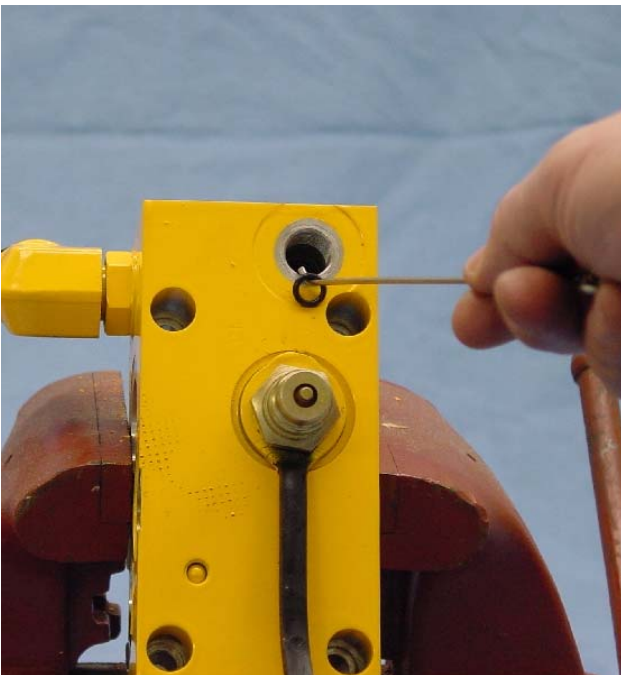

FIGURE 3-55
Remove Bottom O-ring using Special Tool.

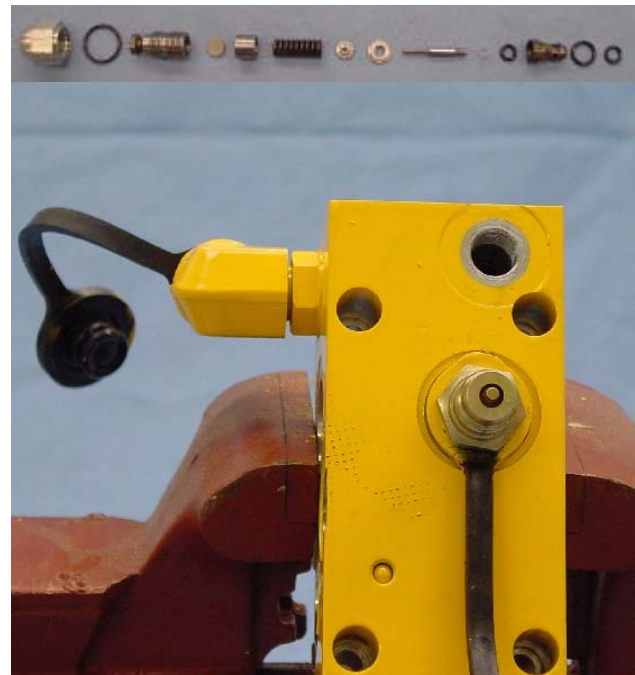

FIGURE 3-56
Correct order when reassembling Crossover Relief Valve.
Note: All parts should be dipped in oil prior to their assembly.

CROSSOVER RELIEF VALVE REASSEMBLY - ALL MODELS

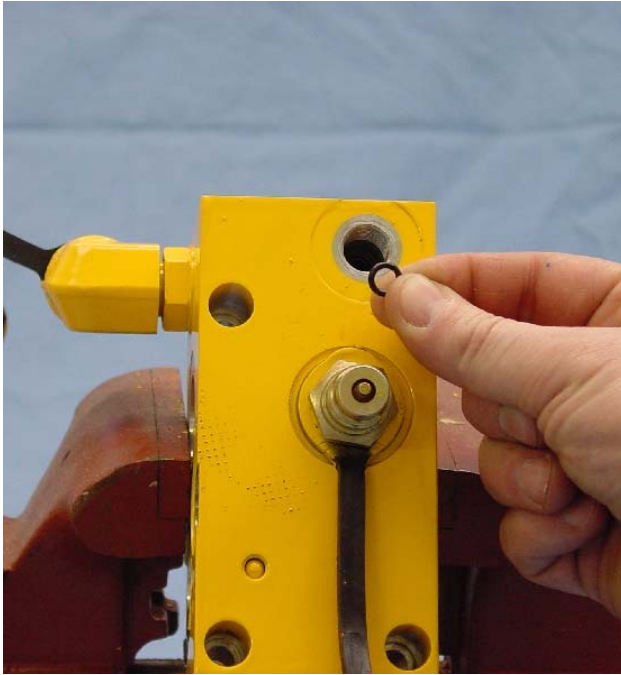

FIGURE 3-57

Reinstall O-ring making certain it is seated to the bottom of the cavity.

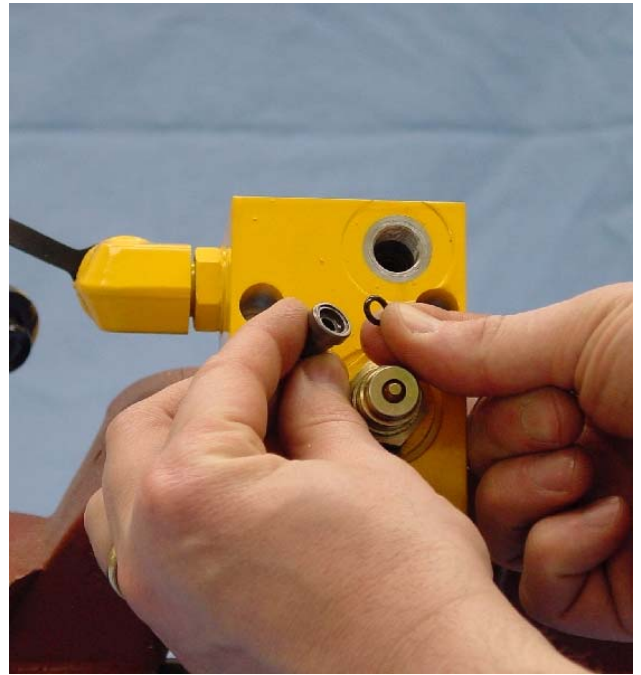

FIGURE 3-58

Install small O-ring into top of Cage.

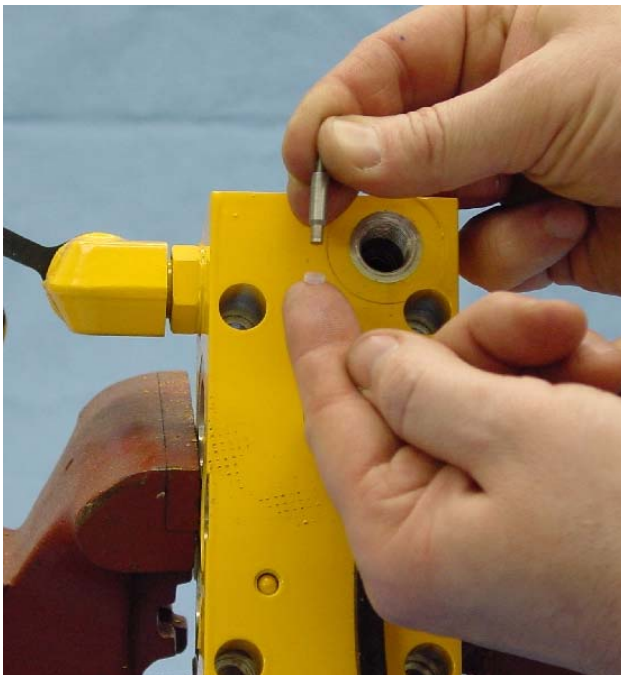

FIGURE 3-59

Install small Bushing onto Poppet.

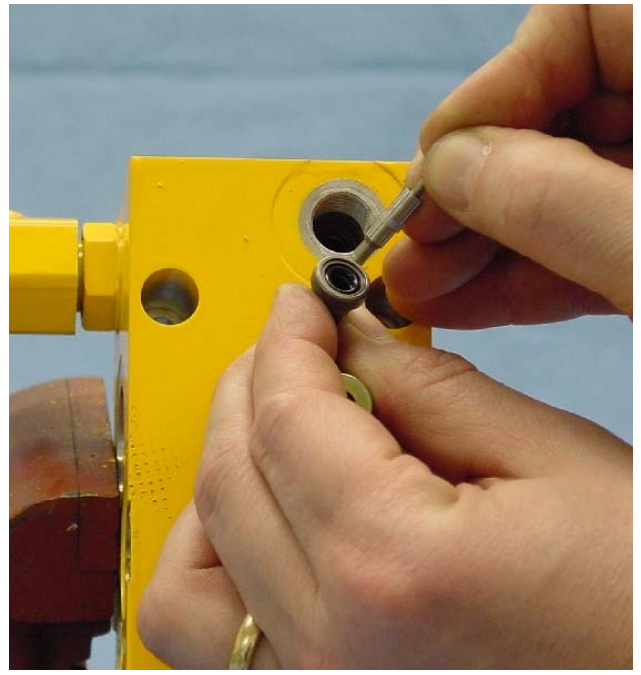

FIGURE 3-60

Assemble Poppet with Bushing into Cage as shown.

CROSSOVER RELIEF VALVE REASSEMBLY - ALL MODELS



FIGURE 3-61

To install Bushing, assemble Washer onto the Poppet as shown. Press Washer down on Cage, this will put equal pressure on the Bushing. Hold Washer in place then remove Poppet from Cage.

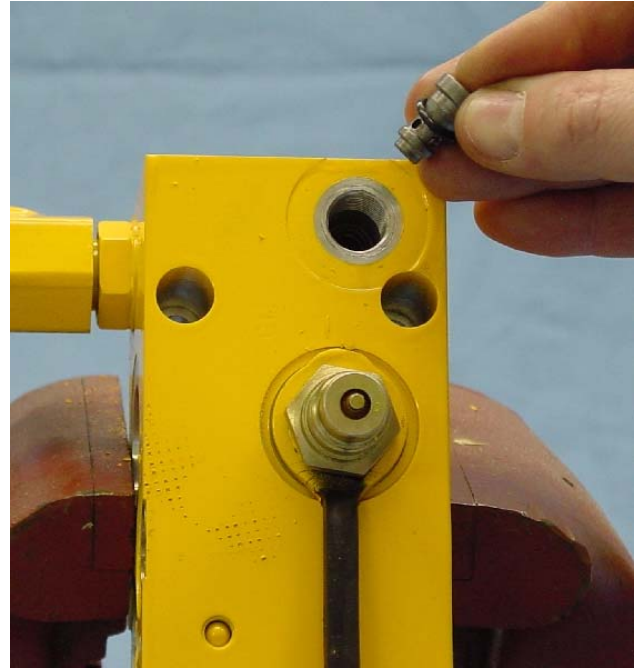

FIGURE 3-62

Slide O-ring over bottom of Cage. Do Not push O-ring completely over shoulder of cage. Drop Cage Assembly into block cavity.



FIGURE 3-63

Seat Cage Assembly to the bottom of the Block Cavity using a drift pin of approximately the same diameter. Tap drift pin lightly until Cage Assembly bottoms out and seals against O-rings.

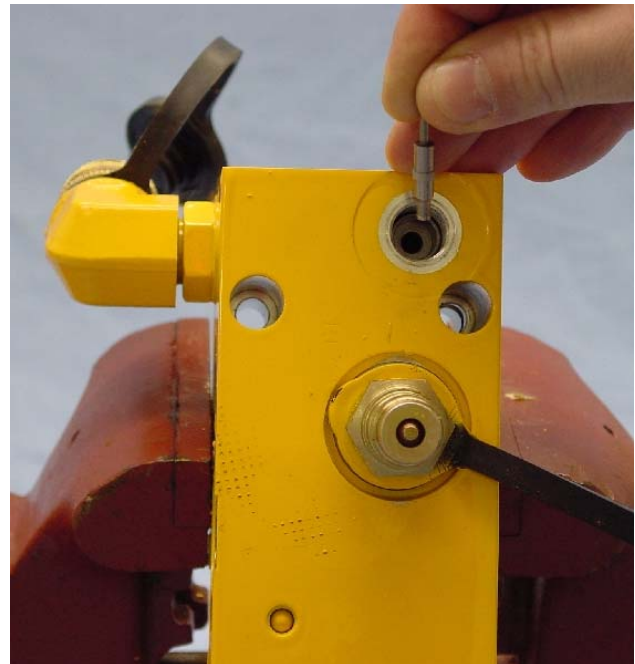

FIGURE 3-64

Reassemble Poppet into Cage.

CROSSOVER RELIEF VALVE REASSEMBLY - ALL MODELS

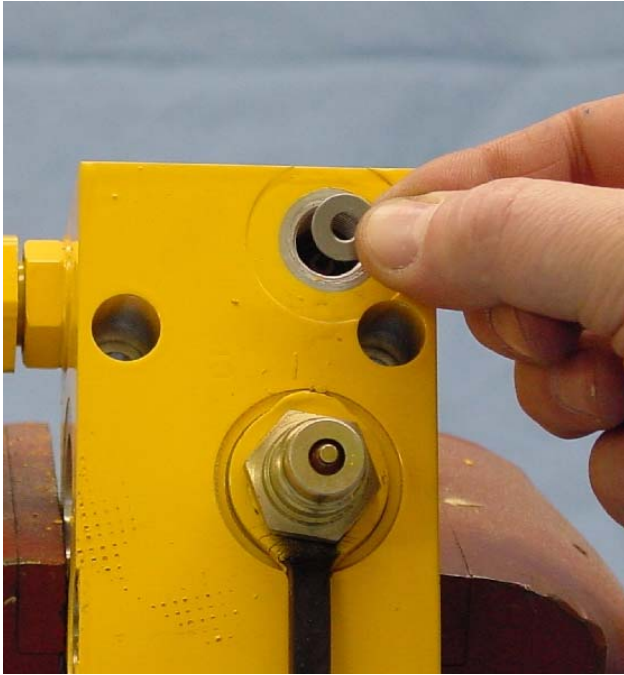

FIGURE 3-65
Reassemble Washer smooth side up.

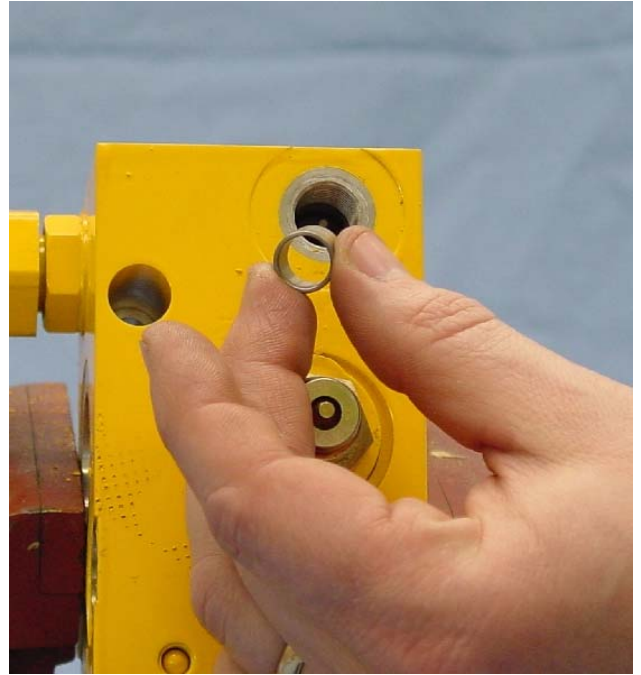

FIGURE 3-66
Assemble Spacer.

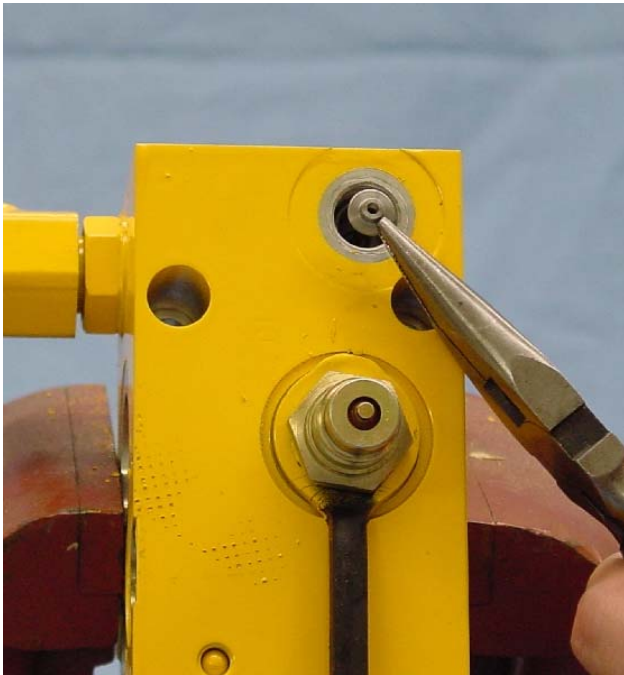

FIGURE 3-67
Reassemble Spring Guide smooth side down.

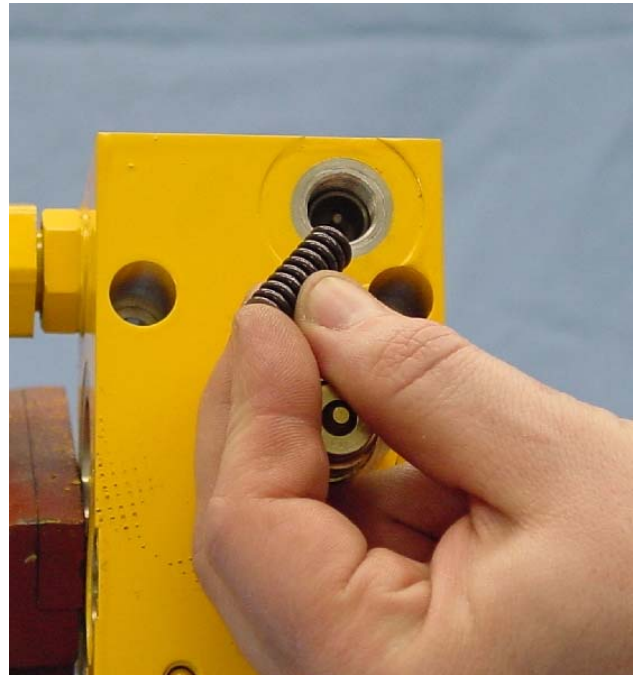

FIGURE 3-68
Reassemble Spring.

CROSSOVER RELIEF VALVE REASSEMBLY - ALL MODELS

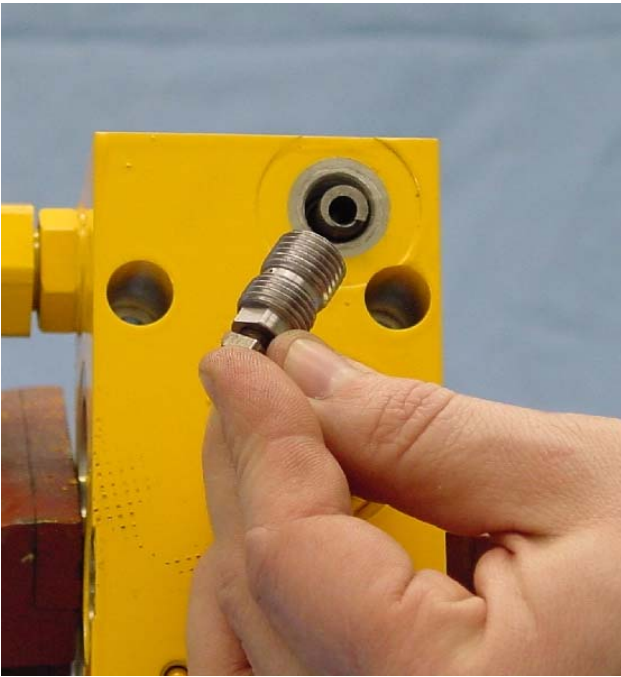
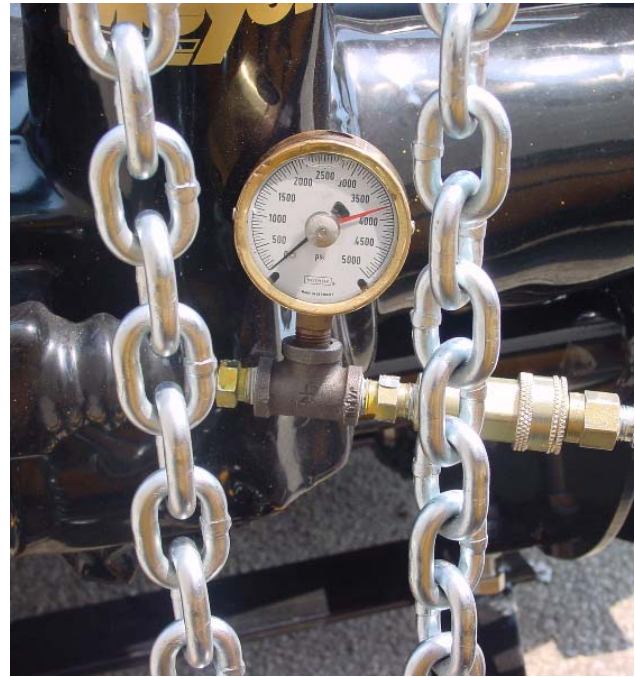

FIGURE 3-69
Reassemble Plug with Adjusting Screw and Disc.



To properly adjust the Crossover Relief Valve refer to page 21. Push leading edge of the Moldboard against an immovable object until Crossover Relief Valve opens. (3800 P.S.I. \pm 400). Reassemble Acorn Nut (61) and O-ring (60).

REASSEMBLY - ALL MODELS

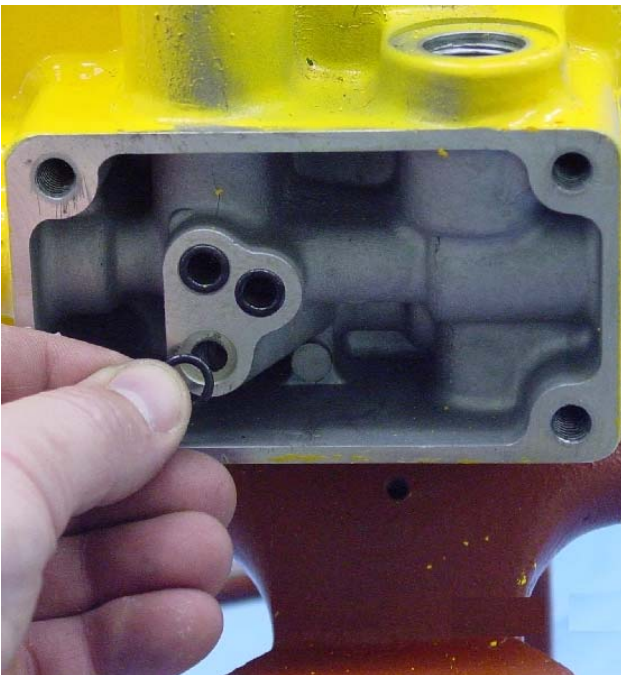

FIGURE 3-70
Install three new O-rings in Sump Base.



FIGURE 3-71
Install P.A. Block Assembly using 5/16-18 x 1-1/2" soc. head screws. Torque to 96-120 in. lbs.

REASSEMBLY - ALL MODELS



FIGURE 3-72

Install Pressure Relief Valve in the order shown.
Note: Torque Seat to 125 in. lbs.



FIGURE 3-73

Install Lower Adjustment Screw, new Filters and
Torque Plugs to 75-85 in. lbs. with a 11/16" hex
socket.



FIGURE 3-74

Install Locator Pin and Pump Check Valve in the
following order as shown.

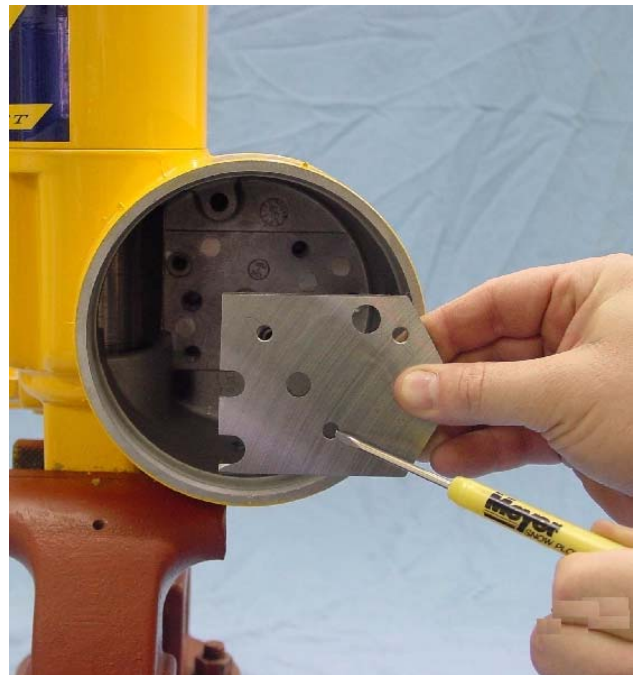

FIGURE 3-75

Install Pump Mounting Plate making certain that the
small hole in plate is directly over the Pump Check
Valve.

REASSEMBLY - ALL MODELS



FIGURE 3-76

Hold Pump Check Valve in place with Special Tool. Install Pump Mounting Plate.



FIGURE 3-77

Install Pump making certain that the dowel pins on the bottom of Pump are aligned with holes located in the Pump Mounting Plate. Torque Pump mounting bolts evenly to ensure proper shaft alignment with the Pump Shaft Seal. Torque bolts to 185 ± 5 in.



FIGURE 3-78

Install Motor Mounting Cover using new Nylite washers and 5/16-18 x 3-1/4" cap screws. Note: motor replacement (Two Terminal) requires new Mounting Plate Part No. 15831. See Fig.3-79



FIGURE 3-79

Torque Cap Screws to 100-125 in. lbs.

REASSEMBLY - ALL MODELS



FIGURE 3-80

Install two terminal motor with power terminals facing up as shown. Torque bolts to 60-72 in. lbs.



FIGURE 3-81

Install single terminal motor with power terminal facing to the rear as shown. Torque bolts to 60-72 in. lbs.



FIGURE 3-82

Install Fenner Motor Cover making certain that the drain holes in the cover are facing downward.



FIGURE 3-83

Install Drain Plug.

REASSEMBLY - ALL MODELS



FIGURE 3-84

Refill unit with Meyer M-1 Fluid 1" to 1-1/2" from Top Cap with Ram all the way down.



FIGURE 3-85

To adjust operating pressure of the hydraulic unit, turn the adjusting screw clockwise to raise the pressure and counter clockwise to lower the pressure.
E-60 (1-1/4" Ram) Set pressure to 2500 ± 50 P.S.I.
E-60 & E-60H Set pressure to 2000 ± 50 P.S.I.

VALVE CARTRIDGE INFORMATION

IMPORTANT: The valve cartridges can be damaged beyond repair by bending or denting the tube, the portion of the cartridge surrounded by the coil. Therefore, do not grip the cartridge tube with pliers or clamp it in a vise.

"A" CARTRIDGE

NOTE: Use only a 7/8" or a 1-1/8" hex deep socket to remove and reinstall the "A" Cartridge.

The "A" Cartridge cannot be disassembled. When operating normally, the poppet can be pushed in approximately .030".

Jamming of the poppet due to metal chips or other contamination can usually be eliminated by immersing the entire cartridge in clean kerosene and pushing the poppet in and out with a probe until it moves freely. Dry with compressed air and reinstall.

In the event jamming cannot be eliminated, replace the cartridge.

VALVE CARTRIDGES "B" and "C"

Use only 1-1/4" hex deep socket to remove Cartridges.

NOTE: Cartridges without a hex nut must use special tool No. 21891 to remove and reinstall the "B" and "C" Cartridges. See Figure 3-89 (page 54).

When jamming of the spool occurs, attempt to eliminate it using the method described under "A" Cartridge before disassembling it.

The "B" and "C" Cartridges can be disassembled by removing the internal retaining ring. When operating normally, the spool can be pushed in approximately .070". However, it is generally a better use of one's time to replace the cartridge. In the event jamming or some other malfunction cannot be eliminated, replace the cartridge since individual parts for it are not available.

BRUSH REPLACEMENT OF ISKRA MOTOR

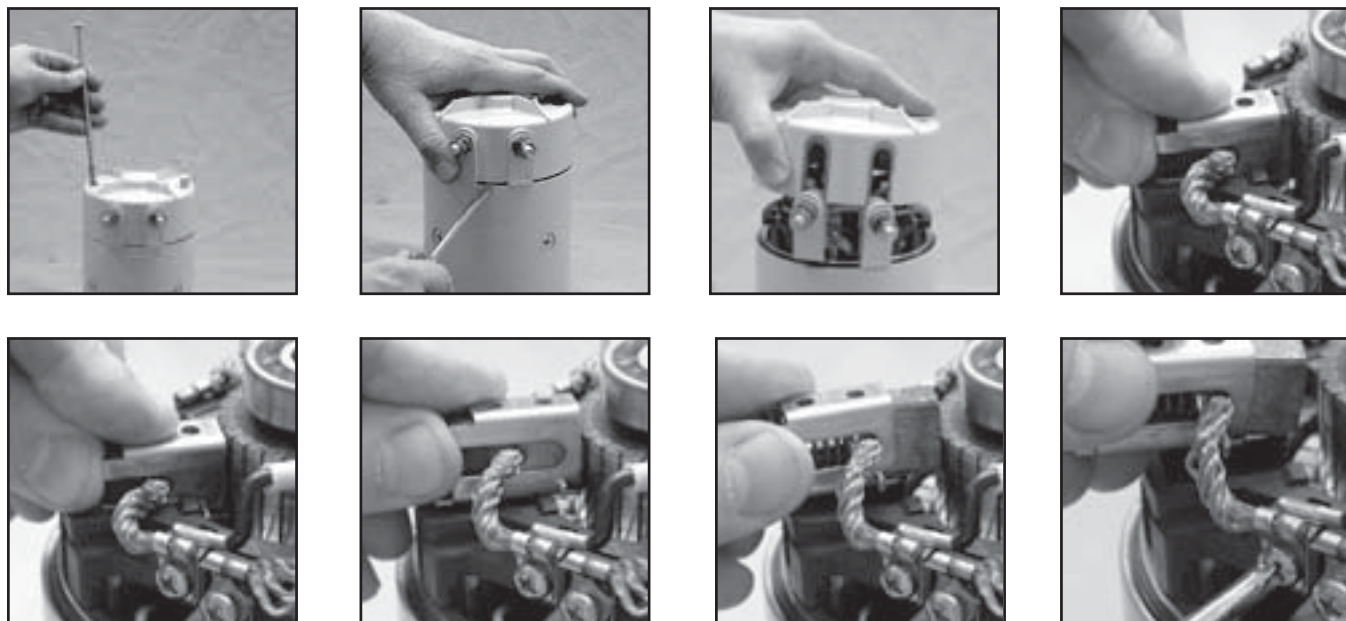

FIGURE 3-86

Remove motor from hydraulic unit. Remove top cap from motor housing. To replace brushes (part # 15854) start by pushing each brush assembly towards the commutator. Remove old assembly from the insulated mounting plate, removing retaining screws. Replace with a new brush assembly by reversing the above procedure. It is recommended that each brush be changed in turn to avoid confusion, make sure that each brush assembly is replaced with the correct part that has the brush cable on the the same side. Service Kits consist of 2 matching pairs of brush assemblies.

BRUSH REPLACEMENT OF FENNER MOTOR

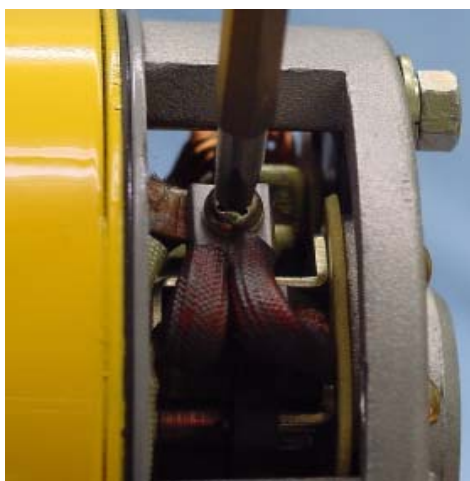

FIGURE 3-87

To remove brushes, first remove screws from brush leads using a phillip head screwdriver.

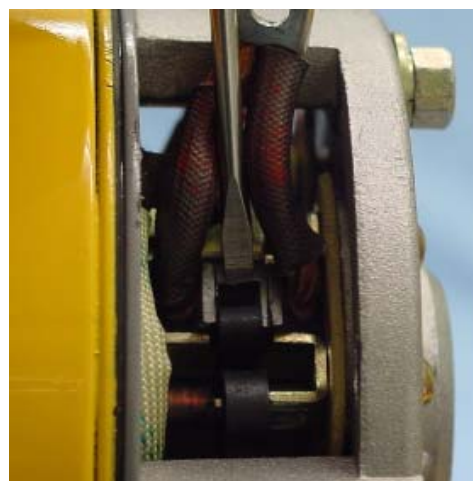

FIGURE 3-88

To remove brushes from motor housing, insert a flat head screwdriver underneath the tension springs. Pry upward and remove brush. Reinstall new brushes in reverse order.

SPECIAL TOOLS

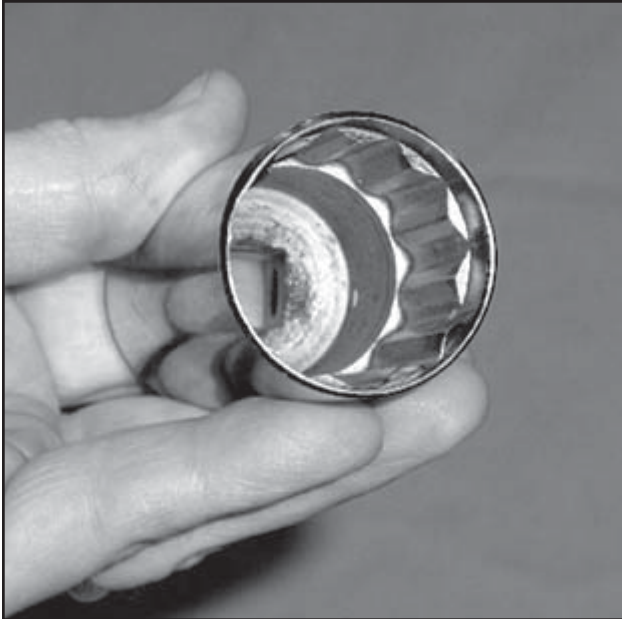

FIGURE 3-89
"B" and "C" Cartridge Tool, #21891.

Crossover Relief Valve

Inner Harden Steel Wire from a Throttle/Choke cable

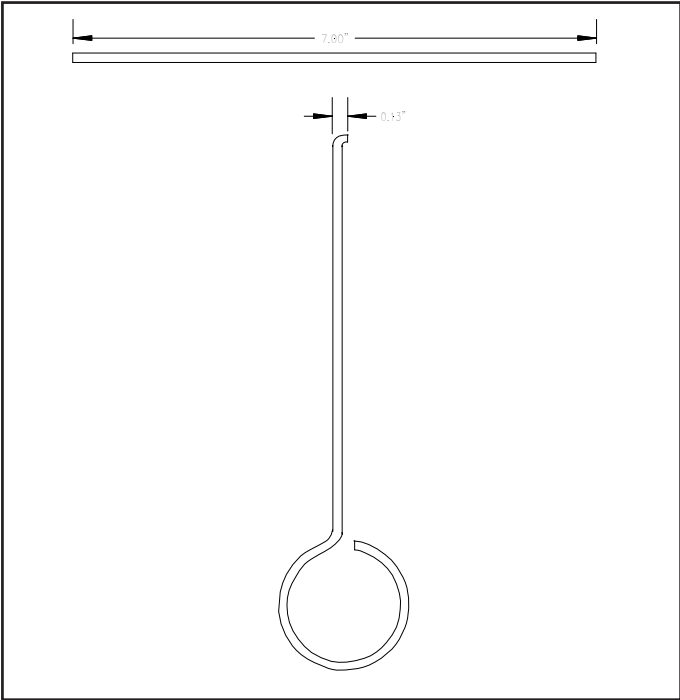

FIGURE 3-90

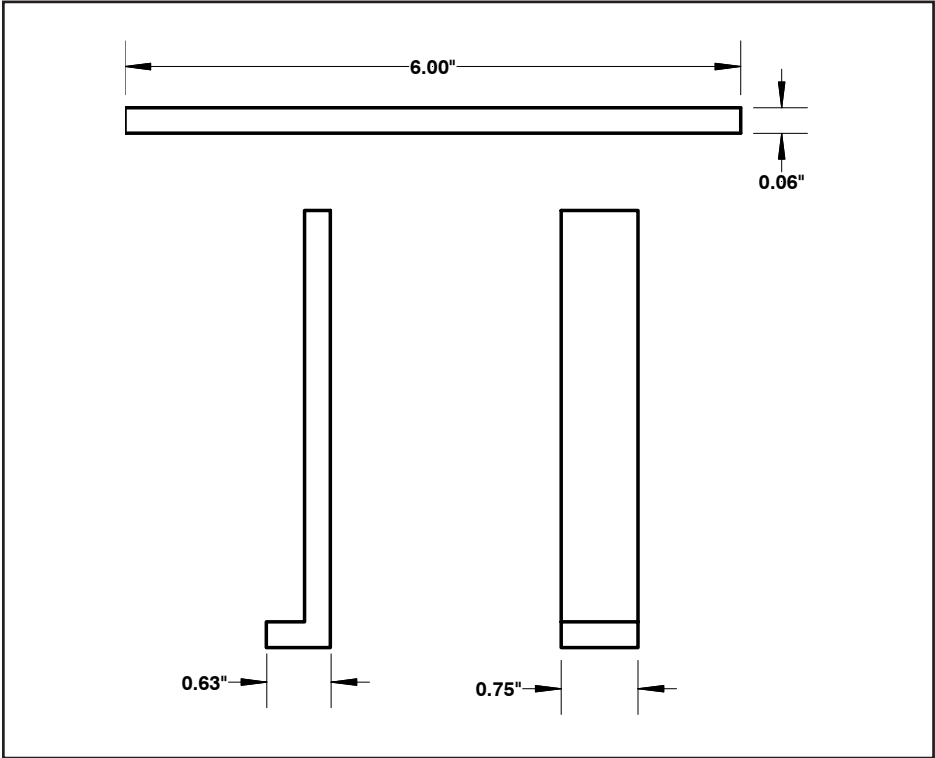

FIGURE 3-91
Pump Check Valve Tool

SECTION 4 - SPECIFICATIONS

ELECTRICAL SPECIFICATIONS

MOTOR

FENNER

No load (motor not attached to pump)

NOTE: Do not operate motor continuously for more than 30 seconds.

Applied Voltage	12 Volts DC
Max. Current Draw	150 Amperes

Speed (Min.)	3,200 RPM
--------------	-----------

Under load (pump operating in relief)

NOTE: Do not operate motor continuously for more than 5 seconds.

Applied Voltage	12 Volts DC
Max. Current Draw	230 Amperes

ISKRA AMJ4739 12V.

No load (motor not attached to pump)

NOTE: Do not operate motor continuously for more than 30 seconds.

Applied Voltage	12 Volts DC
Max. Current Draw	150 Amperes

Speed (Min.)	3,200 RPM
--------------	-----------

Under load (pump operating in relief)

NOTE: Do not operate motor continuously for more than 5 seconds.

Applied Voltage	12 Volts DC
Max. Current Draw	230 Amperes

SOLENOID VALVES :

“A”, Coil

Applied Voltage	12 Volts DC
Current Draw	1.2 Amperes

Nominal resistance (ohm meter lead connected to coil lead, other meter lead connected to metal coil cover) 9.6 ohms \pm 10% Plastic cover Coil 10.0 ohms \pm 10%

”B” and “C” Coils

Applied Voltage	12 Volts DC
Current Draw	1.24 Amperes

Nominal resistance (ohm meter lead connected to coil lead, other meter lead connected to metal coil cover) 3.73 ohms \pm 3%.

SOLENOID SWITCH

Applied Voltage	12 Volts DC
-----------------	-------------

Max. Current Draw	5 Amperes
-------------------	-----------

Nominal resistance (ohm meter lead connected to coil lead, other meter lead connected to metal foot) 2.65 to 4.5 ohms.

HYDRAULIC SPECIFICATIONS

PUMP - Pressure Output

E-60 (1-1/4” Lift Ram)	2500 \pm 50 P.S.I.
------------------------	----------------------

E-60 & E-60H (1-3/4” Lift Ram)	2000 \pm 50 P.S.I.
--------------------------------	----------------------

CROSSOVER RELIEF VALVE

Opening Pressure	3800 P.S.I. \pm 400
------------------	-----------------------

HYDRAULIC FLUID CAPACITY

NOTE :1 Quart = 32 Fluid Ounces

Model E-60

Unit	44 oz.
Hoses & 1-1/2 x 10 Cylinders	16 oz.
Total	1 qt., 28 oz. (60 oz.)

Model E-60

Unit	44 oz.
Hoses & 1-1/2 x 12 Cylinders	19 oz.
Total	1 qt., 31 oz. (63 oz.)

Model E-60H

Unit	48 oz.
Hoses & 2 x 12 Cylinders	28 oz.
Total	2 qt., 12 oz. (76 oz.)

Model E-60H (MDII)

Unit	48 oz.
Hoses & 1-1/2 x 10 Cylinders	16 oz.
Total	2 qt. (64 oz.)

TORQUE SPECIFICATIONS

	<u>Thread Size</u>	<u>Torque (In. Lbs.)</u>
Reservoir Cover		
Retaining Nuts	5/16-24	100-125
Pump Assembly		
Retaining Cap Screws	5/16-24	185 \pm 5
End Plate or Valve Block		
Retaining Cap Screws	5/16-18	96-120
Motor to Pump Retaining		
Cap Screws	1/4-20	45-55
Motor Mounting Plate	5/16-18	100-125
Drain and Filter Plugs	9/16-18	75-85
“A” Coil Retainer Nut		40 \pm 2



QUIK-LIFT® power unit service manual

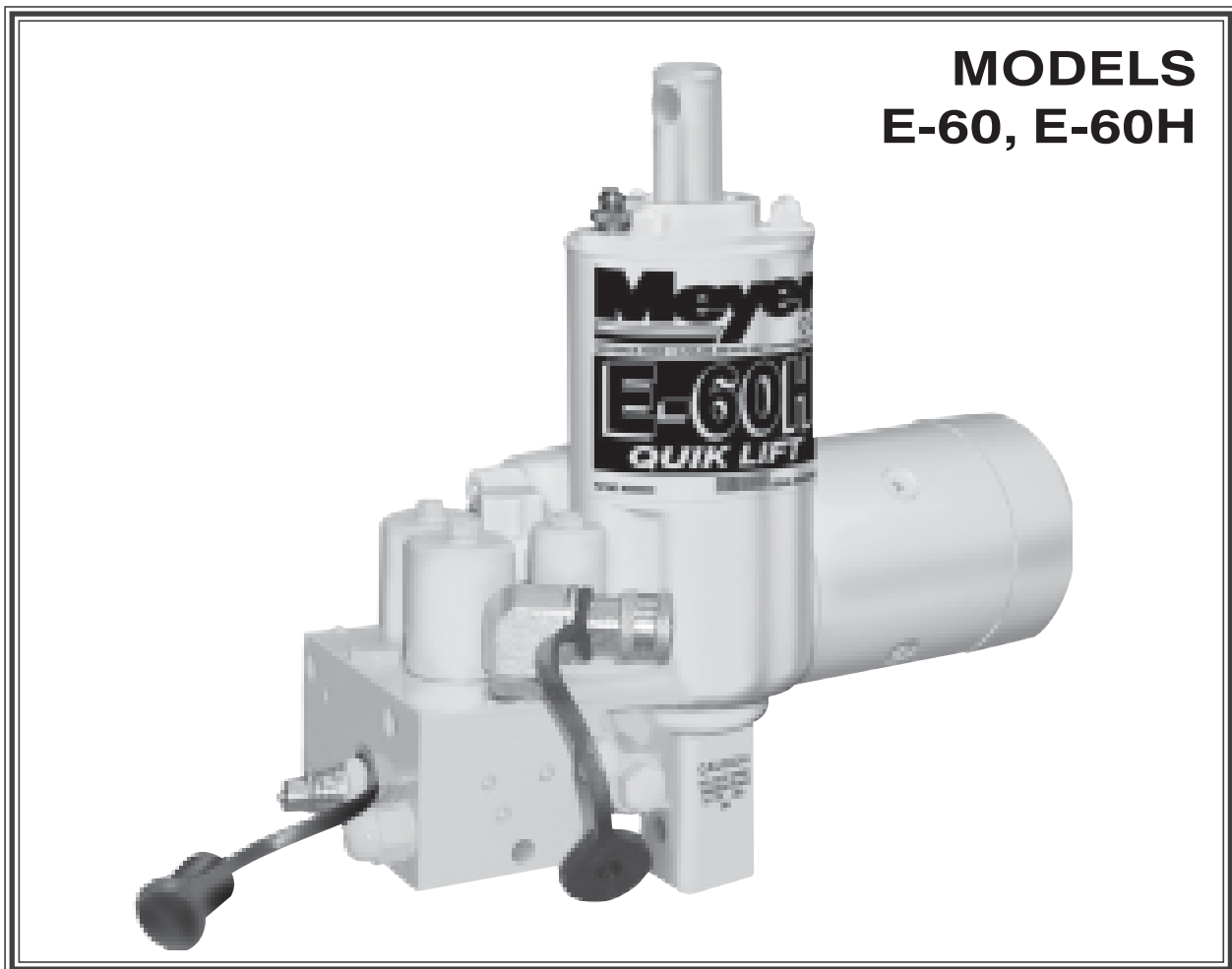

**MODELS
E-60, E-60H**

Meyer Products
18513 Euclid Ave. • Cleveland, OH 44112-1084
Phone (216) 486-1313
email • warranty@meyerproducts.com
© 2005 Printed in the U.S.A.



Diamond Equipment
6 Angell Lane • Damariscotta, ME 04543-9720
Phone (207) 563-2227
www.diamondplow.com • email info@diamondplow.com